

BATHROOM FURNITURE RANGE — BLADE

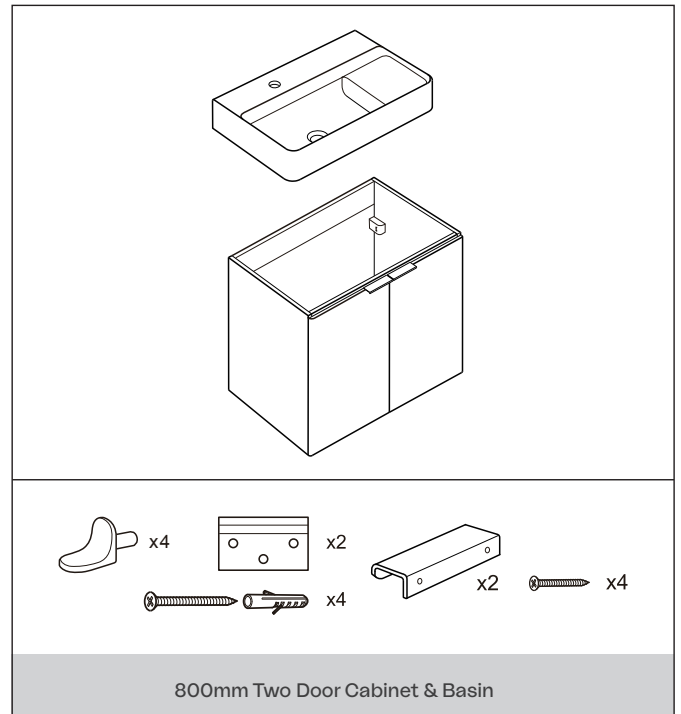
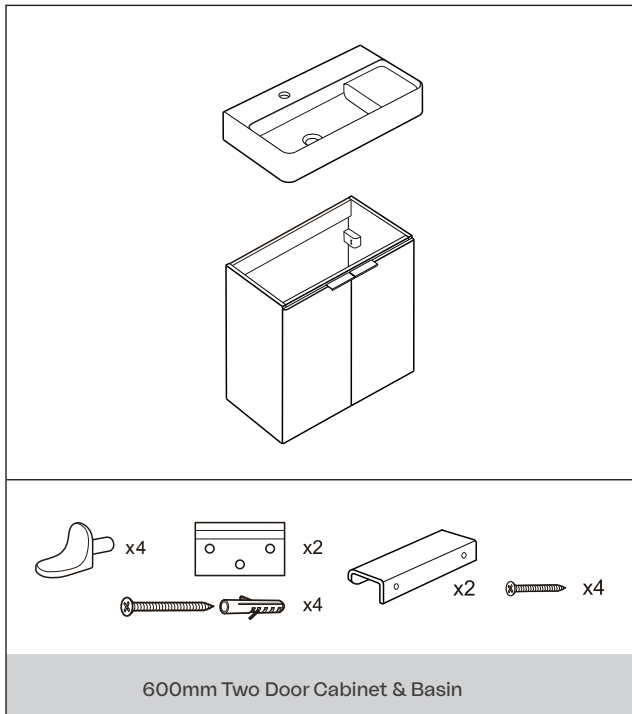

Tools & equipment needed: Drill, 8mm Suitable drill bit, Phillips screwdriver, Spirit level, Ruler/tape measure, Pencil, Silicone sealant (clear).

⚠ IMPORTANT - Advice and safety - Please read before installation

Please read these instructions carefully before starting installation and keep in a safe place for future reference. ENSURE the room is well heated and ventilated.

Check the contents of the pack carefully before installation. Imex will not be held responsible for any de-fit / re-fit costs where faulty product has been fitted.

If any fault is found with materials or workmanship, it must be reported immediately to the manufacturer. Remedial action will be taken, based on information received, on condition that:

1. Full details are supplied to the manufacturer;
2. The product has not been modified or tampered with;
3. The manufacturer is informed of any damage/shortages prior to installation.
4. The product has not been installed, or attempts have been made to install.

We do not accept responsibility for any problems that may occur through incorrect installation.

⚠ Advice & Safety

This product should only be installed by a suitably qualified Plumber/installer. Should the installation be completed by a non-qualified person any product guarantee maybe considered invalid. For a claim made under our warranty written certification of your installers qualifications can be required.

It is advised that all drawers are removed prior to fitting to avoid unnecessary damage occurring.

It is recommended that the furniture and accessories are installed after tiling, ensuring that the product is installed flat to the tile face and allows product to be easily removed if required in the future.

This document has been prepared for your guidance, you must exercise due care at all times.

Please note that some units are heavy. Always take care when lifting, and follow health and safety guidelines. It is recommended that 2 people carry out the installation of larger basin/worktop/ cabinet units.

Warning! Please check for any hidden pipes or electrical cables before drilling holes in the floor or walls.

When using power tools always follow the manufacturer's user instructions.

This installation guide details fitting to a solid wall. If your bathroom has studded/plasterboard walls, please use appropriate plasterboard fixings. Please ensure the wall can take weight of units detailed above. Before installing a wooden bathroom cabinet into a new property, extension or recently plastered room we strongly advise the building/room is completely dry, well ventilated and adequately heated.

Care & Cleaning

In order to keep your furniture looking as good as new please ensure no standing water is left on wooden areas, they will absorb water if excessive water is continually applied to the surface, this will cause damage to the cabinet and will not be covered by our guarantee. You must remove any excess water with immediate effect and keep your furniture as dry as possible at all times, our products are made using the very best materials to avoid as much as possible water ingress but please avoid excessive saturation.

INSTALLATION INSTRUCTIONS

Step 1

Handle installation

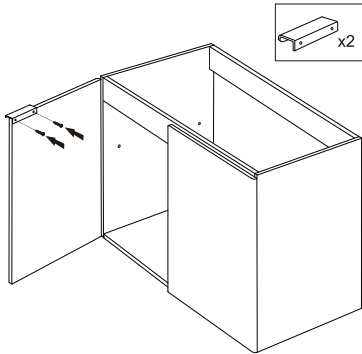

Step 2

Plan cabinet position
Decide on the position and height of the cabinet.

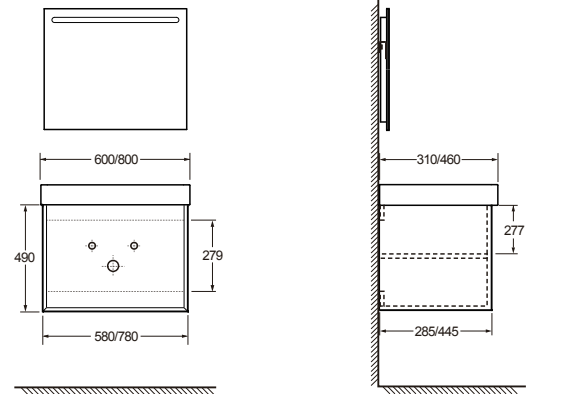

Step 3

'Wall bracket' installation

Use the measurements given, to position the 'wall brackets'.

600mm Cabinet

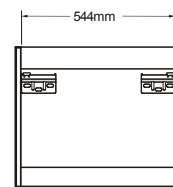

800mm Cabinet

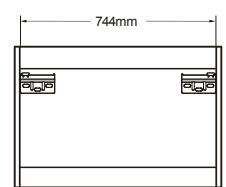

a: Important: The measurements given are the maximum the brackets can be spaced apart, the brackets must fit within that measurement.

b: Mark the bracket fixing holes onto the wall. Drill 8mm holes, insert the wall plugs on solid walls.

c: Attach the brackets.

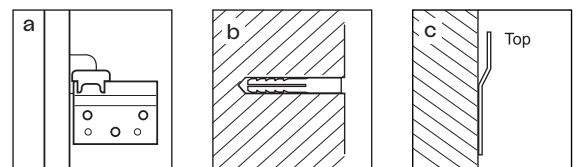

Important: If the cabinet, and/or basin are not fitted level this may result in the basin not draining correctly.

Position the cabinet on the brackets.

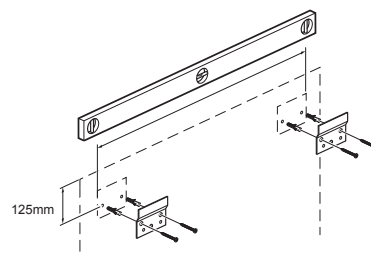

Step 4

a: Check the cabinet is level. If levelling is required, use a screwdriver to adjust the hanging position.

b: Take the cover off. To lift or lower the cabinet, adjust the screw shown.

c: To move the cabinet closer or further from the wall, adjust the screw shown. Put the cover on.

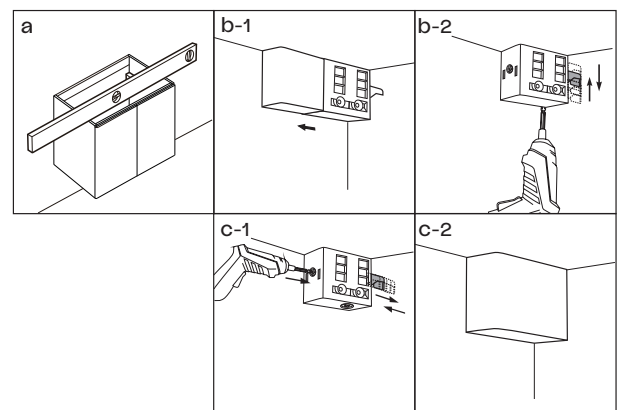

Step 5

a: Attach the tap (not supplied) to basin and carefully bed in the waste (not supplied) using silicone **only**.

b: Run a thin beading of silicone sealant along all contact areas of the cabinet and fit the basin onto the cabinet.

c: Seal around the basin and wall to create a water tight seal.

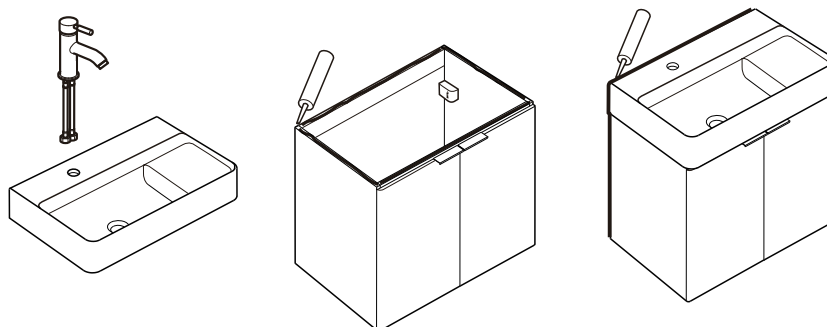

Note: Basin waste and tap fittings when over tightened can create stress within the basin material which may in time cause the failure of the product. Waste fittings should be carefully bedded in silicone and the back nut hand tightened an additional quarter

turn using a suitable spanner is sufficient to create the required watertight seal. Care should also be taken when fitting brassware to tap platforms in order to prevent similar stress related failures.

Step 6

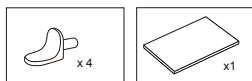

a: Install the shelf brackets, as shown in Figure a, to the corresponding mounting holes on both sides of the cabinet.

b: Put the shelf to the brackets, as shown in Figure b.

c: Align the shelf.

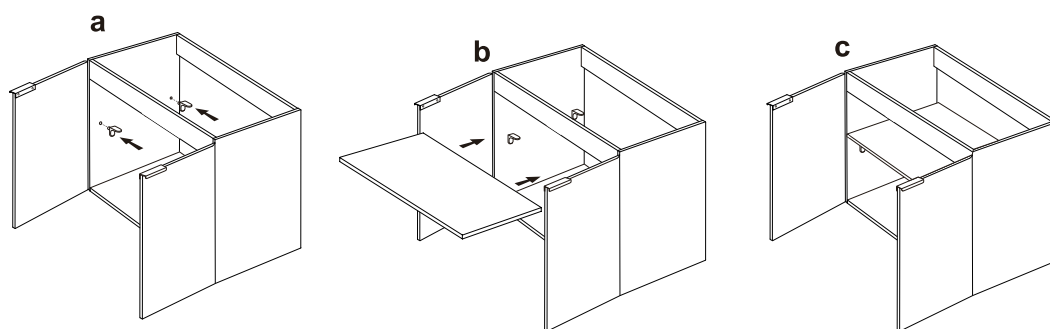

Important information

All ceramic sanitary ware is subject to the limitations of the manufacturing process. Unlike machine finished products, natural clay based products shrink and move during high temperature firing and, because it is not possible to control this process absolutely, minor variations in the dimensional tolerance, form and surface of the finished products will occur.

Before installing a wooden bathroom into a new property, extension or recently plastered room we strongly advise the building/room is completely dry, well ventilated and adequately heated.



Imēx

Manufactured for life

Product Aftercare Guide

Dear Valued Customer,

Thank you for stepping into the world of Imex, a world of elegant design and meticulous attention to detail.

This guide has been created to help you with all aspects of aftercare. The information will ensure your product looks immaculate and functions efficiently, despite its continued and everyday use.

If you have any further questions, please email sales@imexceramic.co.uk or call 01530 835598

Many thanks,

Imex Ceramics UK

Toilet seats

We recommend,

Always clean immediately after use to stop the build-up of dirt and limescale.

Use warm soapy water and rinse down with cold water, wiping down with any soft dry cloth.

A small amount of white vinegar can be used if there is a build-up of limescale.

Please do not...

Under no circumstance should you use household chemicals such as drain cleaners, hair dye, nail varnish remover, paint strippers, strong disinfectants, and household bleach. Some soap and shampoos can permanently discolour acrylic if allowed to pool undiluted for any length of time.

Do not have naked flames or cigarettes near your bath as they can burn and melt the acrylic.

Imex Sanitaryware

We recommend,

Regularly clean your new product with warm soapy water as this will stop the build-up of dirt and harmful limescale, rinse with clean cold water, dry and polish with a clean dry soft cloth.

The occasional use of a mild non abrasive bathroom limescale remover can be used, ensure to rinse off immediately with plenty of clean cold water.

The use of bleach in the toilet bowl is acceptable.

Please do not...

Do not put any bleach products such as bleach blocks into the actual cistern tank as this may damage the internal fittings.

Do not leave strong cleaning products or bleach to stand in or on your product overnight or for any prolonged period .

Do not mix different cleaners as this may cause a chemical reaction and produce harmful gases.

Brass, Chrome, Aluminium, and Stainless Steel fittings

We recommend,

Clean all chrome surfaces immediately after use to stop a build-up of dirt and harmful limescale on your product.

Clean with a warm weak neutral washing up solution, rinse immediately with clean water and dry with a clean soft cloth.

The occasional use of a mild non abrasive bathroom limescale remover can be used, ensure to rinse off immediately with plenty of clean cold water. To remove a build-up of lime scale, we recommend to use a white vinegar solution.

Please do not...

Do not use products that contain abrasive chemicals to clean your brassware. This may cause the materials to corrode which inevitably will void the warranty on the product. If you would like further advise on the recommended cleaning products to use, please contact our customer service team.

Do not scratch the finish as this can leave your product vulnerable to corrosion.

WC maintenance

If there is water flowing into your WC bowl lasting for longer than five minutes after flushing please see the maintenance procedure over the page or read the following for further details:

- The float height on the inlet valve may have moved or been set too high and causing water to internally overflow into the pan (please refer to the installation details that came with your cistern) or ask your installer.
- There may be a build-up of scale or debris on the diaphragm washer on the base of the central column or flush valve. Try cleaning the diaphragm washer in a warm soapy solution. If this does not rectify the problem please see overleaf for our step by step instructions on how to change the diaphragm washer.
- The push rods which actuate the flush valve may need turning slightly so to make a clean contact with the green flush valve paddles. The flush valve mechanism itself may have been overtightened causing it to distort and preventing the diaphragm washer from sealing.
- If your pan and cistern has been installed on an un-level surface it may be causing the Flush valve mechanism to foul against the side of the valve body. If this is the case the pan and cistern should be reinstalled on a clean level surface.
- If a sealant or mastic was used during the installation this may have chemically attacked the component part(s).
- Cleaning products such as bleach blocks may have been used which have chemically damaged the component fittings.

WC Maintenance procedure

1. Turn off the water supply to the cistern and flush to empty the cistern tank.
2. Close toilet seat and lid.
3. Lift off the cistern lid.
4. Lift out the large button
5. Turn the flush valve $\frac{1}{4}$ turn and lift out exposing the valve seal (diaphragm washer).
6. Grip the rubber diaphragm washer and pull off from the rest of the flush valve.
7. Inspect the rubber diaphragm washer, clean or replace as necessary
8. Refit the valve in reversal of removal ensuring to locate valve body so it clicks into place.
9. Refit the cistern lid ensuring the push button rods actuate the flush valve small button for $\frac{1}{2}$ flush and large button for full flush.

Bathroom Furniture maintenance

We recommend,

By following our simple guidelines, your Imex furniture will provide you with many years of service.

Imex furniture should be treated and handled with care.

After installation all sawdust must be removed with a vacuum cleaner. Please inspect all draw runners and remove any dirt particles to promote a clean smooth running motion.

Wipe away any water splashes or condensation immediately after use.

Prolonged exposure to water may deteriorate the furniture.

Your bathroom should be well ventilated with a suitable extractor fan.

Clean regularly and only with a soft damp clean cloth. Use only a clean soft cloth to polish the finished surface.

For removal of lime scale deposits use a very small amount of a suitable proprietary cleaner and test on a small inconspicuous area first.

Please do not...

Do not scrub or scour

Do not use abrasive cleaning agents

Bathroom Mirrors

Imex mirrors incorporate a safety film backed glass.

You should not fit a mirror directly above a bath or in a shower cubicle.

The glass thickness on all Imex mirrors is 5mm.

Do not place the corners of your mirror on the floor or strike the glass with hard or sharp object.

Do not place very hot or very cold items against or in close proximity to your mirror unless an adequate insulation material is used to prevent any such item from coming in contact with the mirror.

Cleaning

Clean with a soft damp cloth or leather with washing up liquid.
Do not use abrasive cleaning agents such as powder cleaners

Guarantee information

We guarantee our products against faulty materials or manufacture for 10 years on all bathroom furniture.

For 25 years on all Sanitaryware provided it has been installed, used and regularly maintained in accordance with our instructions. All working parts such as hinges, seals and cistern fittings, which are subject to normal wear and tear, are covered for 12 months from proof of purchase date.

Our guarantee applies to the original purchaser only and is non-transferable.

Should you raise a claim, the issue will be investigated. As part of the investigation we request that the following conditions be satisfied:

- Proof of purchase at the time of claim.
- The product has been maintained and cared for in compliance with our instructions (including regular and appropriate cleaning).
- If in our opinion the product has been modified, misused or accidentally damaged, we can accept no responsibility for failure.
- The opportunity to inspect the product in the installed condition.

Faulty items will be replaced with our nearest equivalent product.

This guarantee does not affect your statutory rights.

This guarantee is only applicable in the UK and Republic of Ireland.

Spare components

Should you require a spare component(s) for any of our products please contact Imex Ceramics UK using the contact details overleaf. We carry a full and extensive range of spare parts and are normally able to offer same day dispatch (please allow 48hrs for delivery). We do have a policy of replacing any damaged part with a spare part where possible. Complete exchanges will only be made if the damage is extensive or irreparable.