

# Kaldera 56 UB-KAL-56-IO

Top view

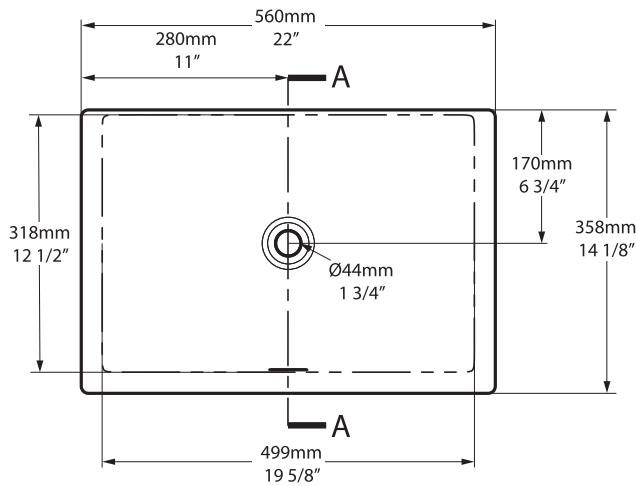

Side view

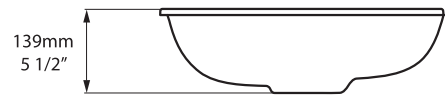

Front view



Section AA

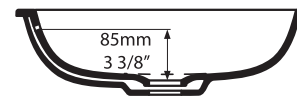

Features an internal overflow  
 Integrierter Überlauf  
 Dispose d'un trop-plein interne  
 Incluye el rebosadero integrado  
 Caratterizzato da un troppopieno interno



**Qc** rich in  
 Volcanic  
 Limestone™

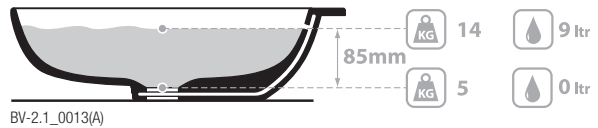

BV-2.1\_0013(A)

Recommended wastes: K-22-xx / K-24-xx / K-25-xx / K-122-xx

\*All measurements subject to +/-5% tolerance

**25**  
 years

Guaranteed for residential use for 25 years  
 25 Jahre Garantie bei privater Nutzung  
 25 ans de garantie pour un usage domestique  
 Garantía de 25 años para uso domestico  
 La sicurezza garantita per uso residenziale per 25 anni

**8**  
 years

Guaranteed for commercial use for 8 years  
 8 Jahre Garantie bei gewerblicher Nutzung  
 8 ans de garantie pour un usage commercial  
 Garantía de 8 años para uso comercial  
 La sicurezza garantita per uso commerciale per 8 anni



Massachusetts Code: Pending  
 cUPC listing by IAPMO: File No. 6970

# Kaldera 62 UB-KAL-62-IO

Top view

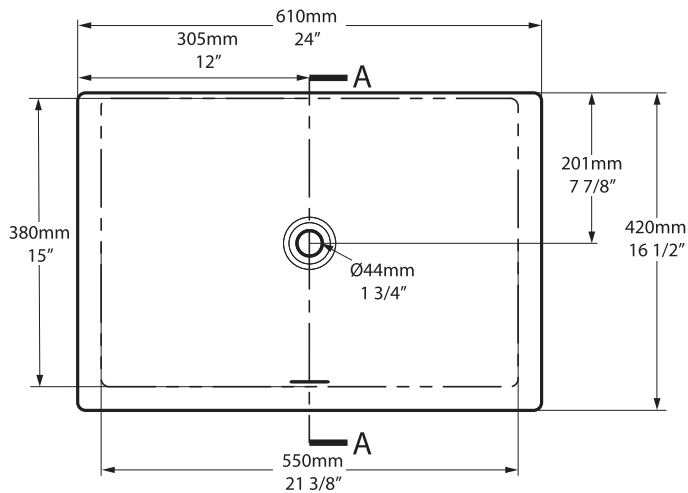

Side view



Front view



Section AA

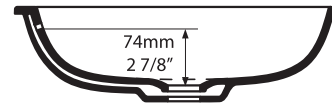

Features an internal overflow  
 Integrierter Überlauf  
 Dispose d'un trop-plein interne  
 Incluye el rebosadero integrado  
 Caratterizzato da un troppopieno interno

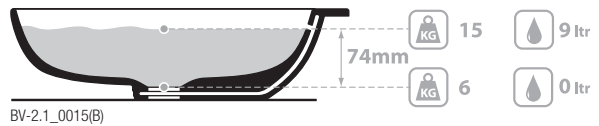

BV-2.1\_0015(B)

Recommended wastes: K-22-xx / K-24-xx / K-25-xx / K-122-xx



\*All measurements subject to +/-5% tolerance



Guaranteed for residential use for 25 years  
 25 Jahre Garantie bei privater Nutzung  
 25 ans de garantie pour un usage domestique  
 Garantía de 25 años para uso domestico  
 La sicurezza garantita per uso residenziale per 25 anni



Guaranteed for commercial use for 8 years  
 8 Jahre Garantie bei gewerblicher Nutzung  
 8 ans de garantie pour un usage commercial  
 Garantía de 8 años para uso comercial  
 La sicurezza garantita per uso commerciale per 8 anni



Massachusetts Code: Pending  
 cUPC listing by IAPMO: File No. 6970