

CUSTOMER SPECIFICATION SHEET - WASTES & EXTRAS

SALES CODE: CMA055

DESCRIPTION: Victrion Double Corner Shower Basket

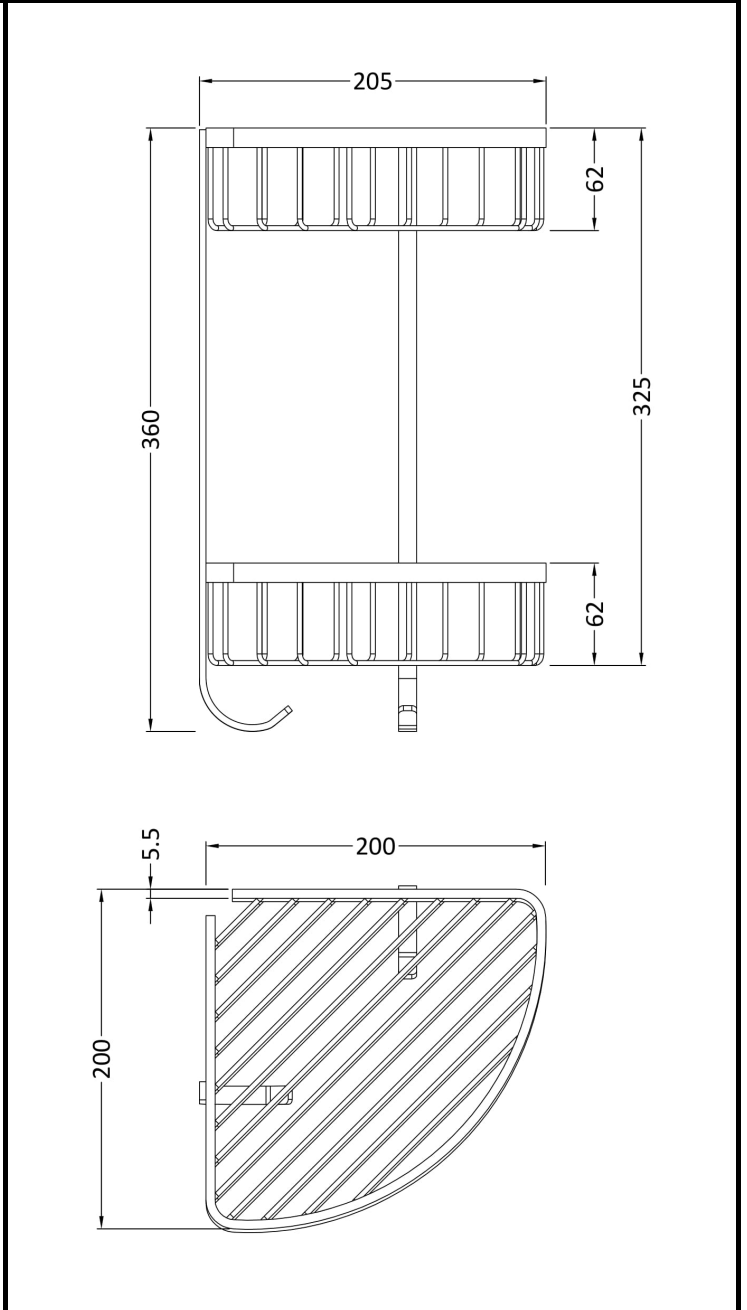

PRODUCT DIMENSIONS

Height (mm)	Width (mm)	Length (mm)	Depth (mm)	Nett Wgt Kg
360	200		205	

PACKAGING DIMENSIONS

Height (mm)	Width (mm)	Depth (mm)	Gross Wgt Kg

PACKAGING DATA

Box Colour	White Cardboard Box		
Box Qty	1	Label Colour	White Label
Label Size	100 x 50	Label Qty	2

OUTER BOX DIMENSIONS (If Applicable)

Height (mm)	Width (mm)	Length (mm)	Depth (mm)	Gross Wgt Kg
Barcode				

PRODUCT DETAILS

Country of Origin	China
Fitting Instruction	No
Product Material	Brass
Heating Element Wattage	Not Applicable

CE Certification	N/A
Colour/Finish	Chrome
Product Diameter	Not Applicable
Connection Size	Not Applicable