

SPECIFICATION SHEET

COLLECTION: ATMOSPHERE

PRODUCT CODE: ATM-SFSRK/2-C/P



DESCRIPTION:

slide rail shower kit
with single function air-injection handset
805mm slide rail with twist control
900mm overall rail length
with 150cm smooth hose
minimum operating pressure 0.2 bar LP

FINISH:

Chrome

FLOW REGULATOR:

FR-SHOWER/9-C/P

MINIMUM OPERATING PRESSURE:

0.2 bar LP

FLOW RATE AT 3.0 BAR FLOW PRESSURE:

14 l/min

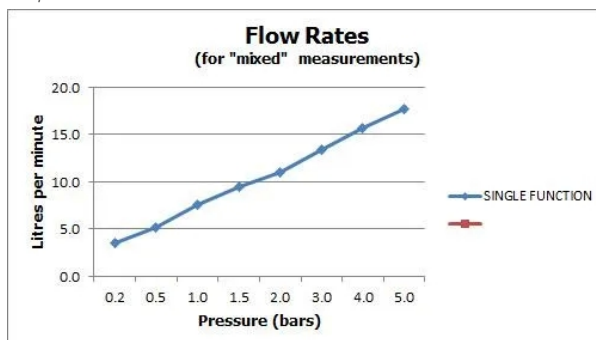

tel: 01934 744466
email: sales@vado.com
www.vado.com

where inspiration flows
taps | showering | accessories



TECHNICAL DRAWING

COLLECTION: ATMOSPHERE

PRODUCT CODE: ATM-SFSRK/2-C/P

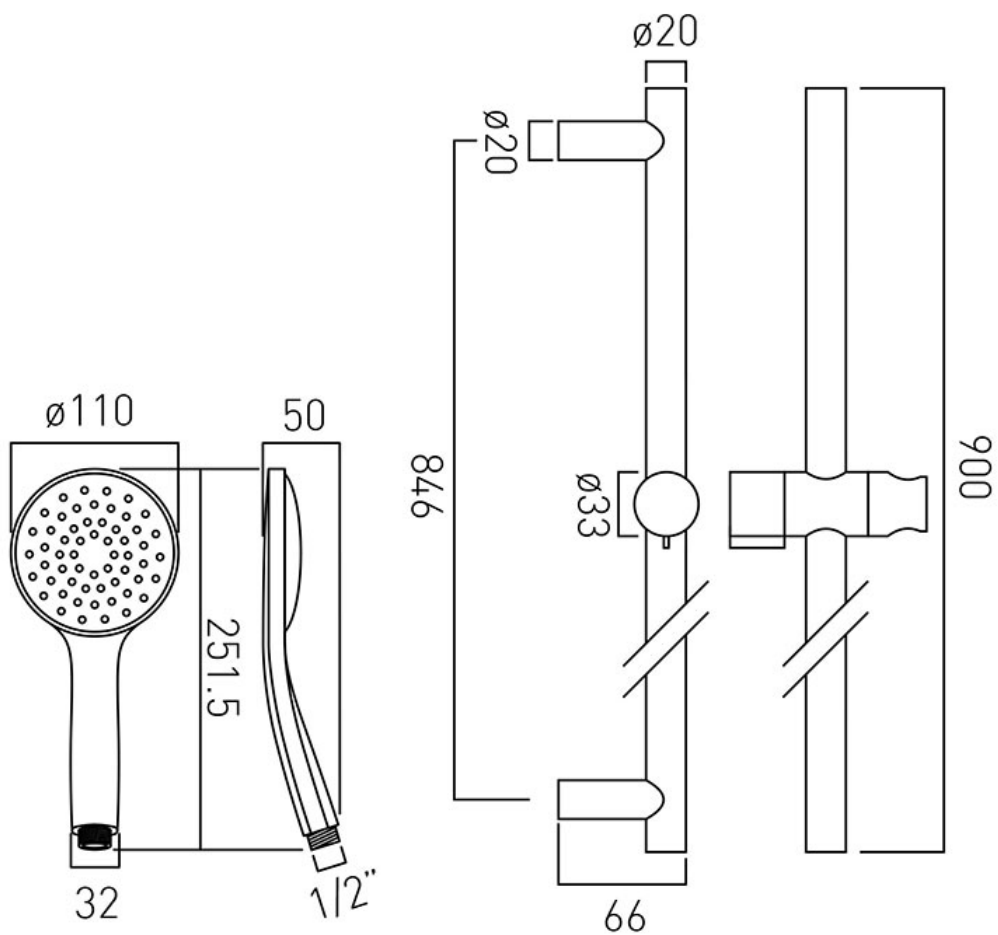

tel: 01934 744466
email: sales@vado.com
www.vado.com

where inspiration flows
taps | showering | accessories

