

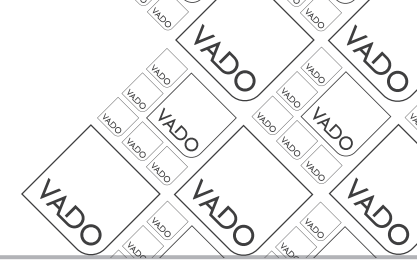

where inspiration flows



## Installation Guide

Thermostatic shower valve with adjustable rigid riser

This instruction booklet covers model:

VEL-149RRK-RO-CP  
AQB-149RRK-RO-CP  
ATM-149RRK-RO-CP

VEL-149RRK-RO-CP  
AQB-149RRK-RO-CP  
ATM-149RRK-RO-CP

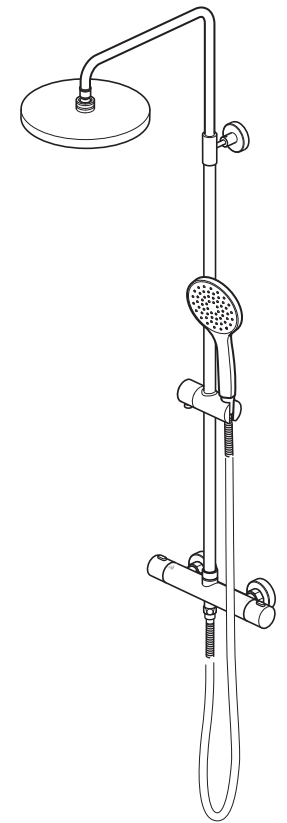

Note: for illustrative purposes only the VEL model is shown.  
Please follow the same procedure to install the AQB & ATM.



Keep for future reference

Vado  
Wedmore Road, Cheddar, Somerset, England BS27 3EB  
tel 01934 744466. fax 01934 744345  
aftersales@vado.com  
www.vado.com

## Contents

Important information.....	3
General installation.....	3
Operating Specifications .....	3
Contents of packaging .....	4
Dimensions.....	6
Installation - Quick guide.....	7
Installation - Off-set connectors .....	12
Installation - Quick -fit connectors.....	13
Installation - Shower hose.....	17
Commissioning.....	18

## Notes

## Commissioning

The valve has been factory set under balance pressures and hot water supply at 65°C. When your specific operating conditions are significantly different from the above, the temperature of the water may vary from the setting.

When the difference is too great, you can adjust the calibration of the valve to suit individual requirements of the installation:

1. Check the temperature of the water being delivered from the outlet with a thermometer.

**Note:** temperature readings should be taken at normal flow rate after allowing for the system to stabilise.

2. If the temperature is not 38°C proceed to reset the calibration as follows.

Remove the handle.

Ensure the step on the stop ring is located at 12 o'clock.

Do not remove the plastic stop ring. Turn the spline of the thermostatic valve clockwise to decrease the temperature and anti-clockwise to increase the temperature until 38°C is achieved at outlet.

**Note:** the sensing part of the thermometer probe must be fully submerged in the water that is to be tested.

Replace the handle making sure that the pin is against the step.

Once the handle has been attached ensure the temperature does not exceed 46°C when turned entirely anti-clockwise.

Your valve setting is now commissioned.

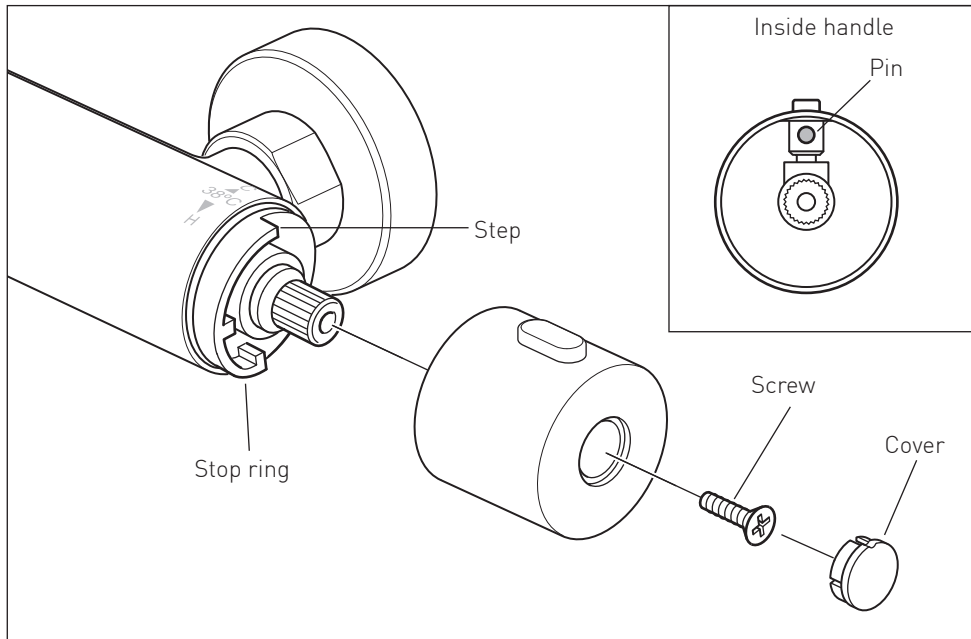

## Important - please read

Please read these instructions carefully before starting installation and keep for future reference.

Remove all packaging and check the product for missing parts or damage before starting installation.

Any alterations made to this product and fittings may infringe water regulations and will invalidate the guarantee.

The installation must comply with all Local/National Water Supply Authority Regulations/Byelaws and Building and Plumbing Regulations.

To be installed in accordance with BS EN806.

We strongly recommend that you use a qualified and registered plumber.

## General installation

This fitting is a mixing device and therefore water supplies should be reasonably balanced.

When installed, the fitting must comply with the requirements of the Water Supply (Water Fittings) Regulations 1999 and Scottish Byelaws 2004.

For further information, contact the Water Regulations department of your local water supplier (see the WRAS website [www.wras.co.uk](http://www.wras.co.uk) for details) or the Water Regulations Advisory Scheme by email ([info@wras.co.uk](mailto:info@wras.co.uk)) or telephone: 01495848454.

Before making any inlet pipe connections, all supply pipes MUST be thoroughly flushed to remove debris. Failure to do so could result in damage or low flow from the mixer unit. Water Supply (Water Fittings) Regulations 1999 Schedule 2 Section 13.

The fitting of isolating valves to the inlet feeds is advised for ease of maintenance.

Please take great care when installing this mixer not to damage its surface.

Please note if installing in an enclosed environment, access should be left for servicing and maintenance. No costs relating to inadequate access can be accepted.

## Operating Specifications

### Operating Pressure

**Minimum operating pressure** 1 bar

**Maximum operating pressure** 5 bar

# Contents of Packaging



**Installation guide & User manual**

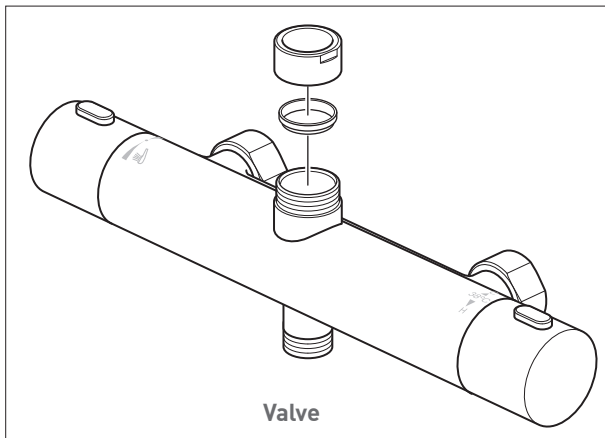

**Valve**

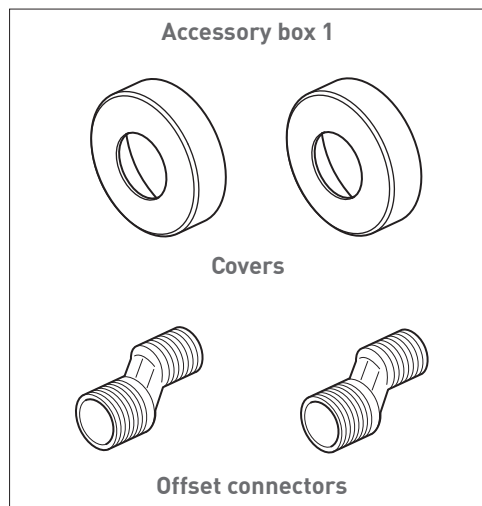

**Accessory box 1**

**Covers**

**Offset connectors**

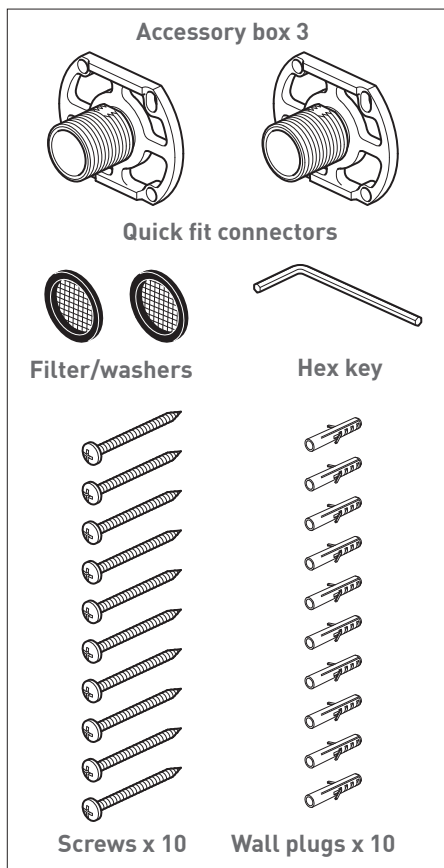

**Accessory box 3**

**Quick fit connectors**

**Filter/washers**

**Hex key**

**Screws x 10**

**Wall plugs x 10**

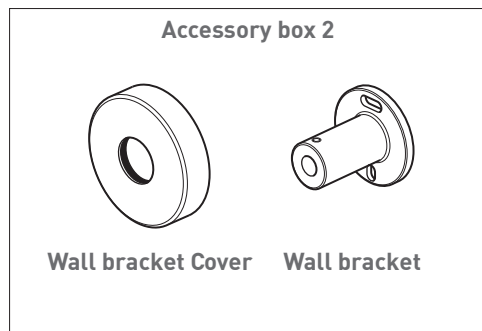

**Accessory box 2**

**Wall bracket Cover Wall bracket**

# Installation - Shower hose

## Shower head

Make sure there is a rubber washer in place in the shower head and screw onto the riser arm.

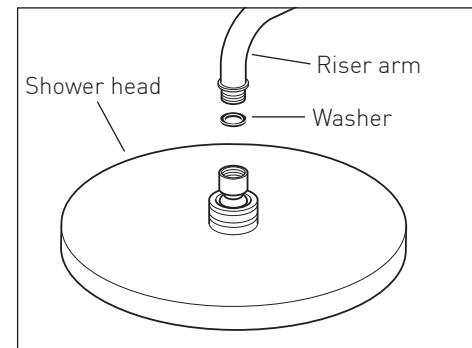

**Shower head**

**Riser arm**

**Washer**

## Handset

Place one of the rubber washer into the cone end of the hose and screw to the handset.

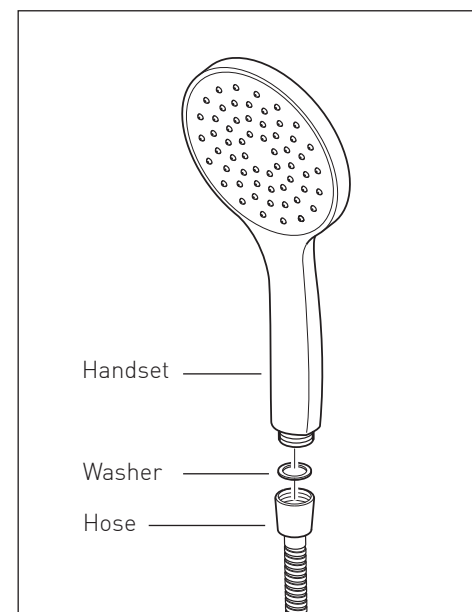

**Handset**

**Washer**

**Hose**

## Valve

Place the second rubber washer into the nut end of the hose and attach it to the valve outlet.

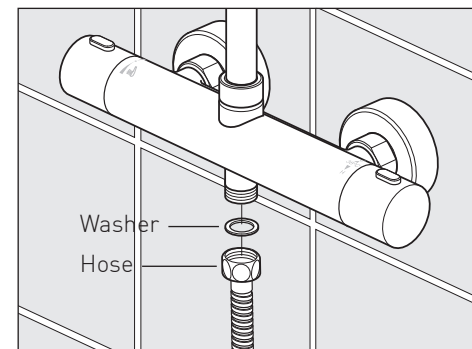

**Washer**

**Hose**

## Installation - Riser rail

Place the bracket against the wall. Make sure that the riser is vertical, mark the two fixing holes in the wall bracket with a pencil.

**⚠ Warning!** Please check for any hidden cables and pipes before drilling holes in the wall.

Remove the riser from the wall and the valve. Drill the marked holes to a suitable depth for the wall plugs and secure with supplied screws.

Slide on the cover.

Push the riser onto the connection on the top of the valve, slide down the seal and tighten the nut.

Using a level secure the wall bracket in position. Tighten the grub screw on the top of the wall bracket.

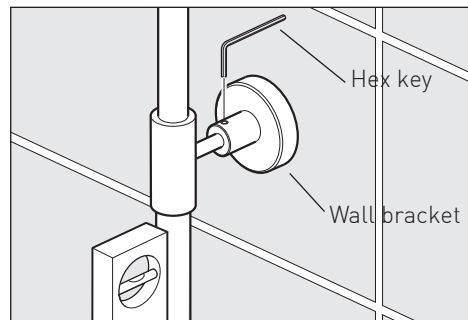
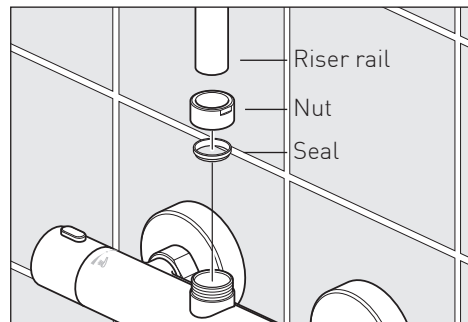
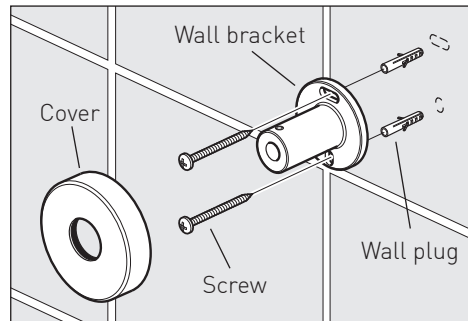
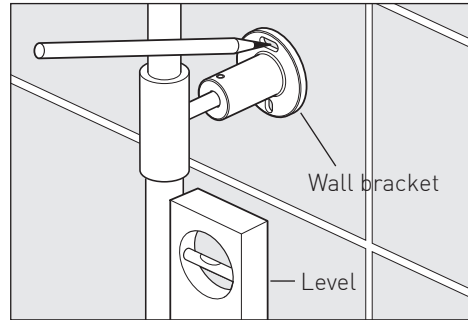

## Contents of Packaging

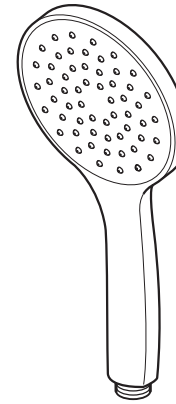

**Handset**

Handset may vary according to model

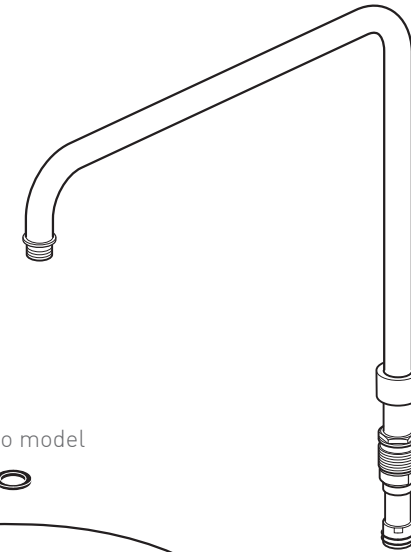

**Riser arm**

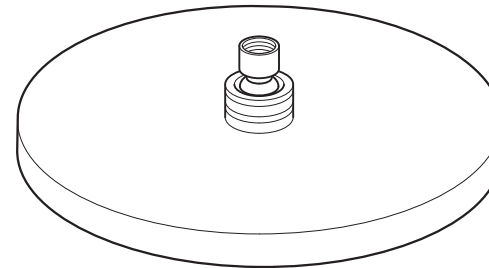

**Shower head** (with a rubber washer)

Shower head may vary according to model

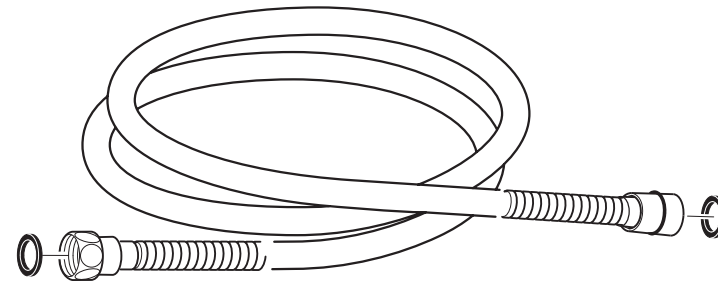

**Shower hose**  
with 2 washers

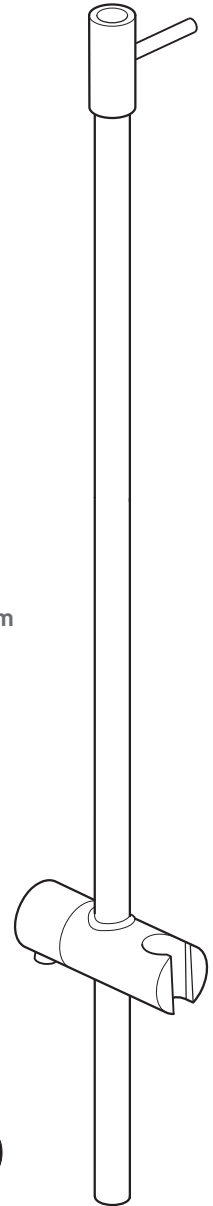

**Riser**

## Dimensions

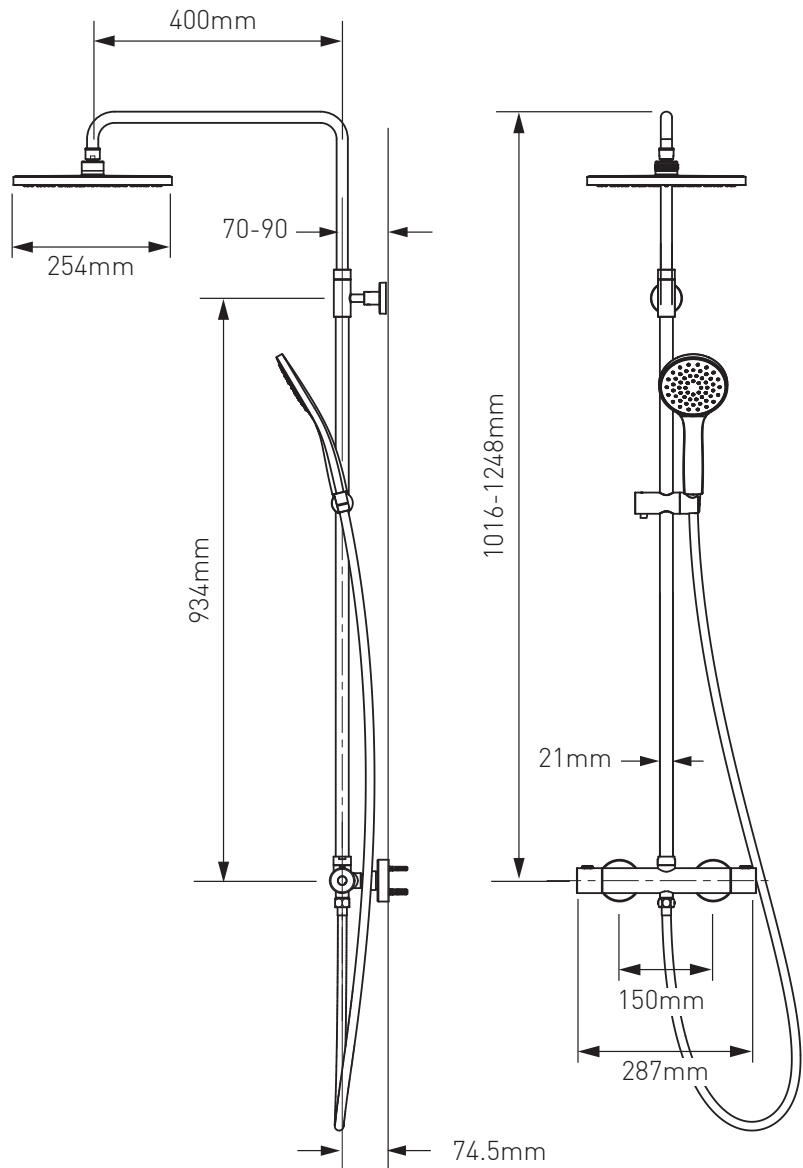

## Installation - Riser rail

You can adjust the height of the riser to suit your requirements.

Carefully push the riser arm into the riser until you reach the required position. Slide the securing nut down and into the riser, tighten the nut.

Pull the cover down over the nut.

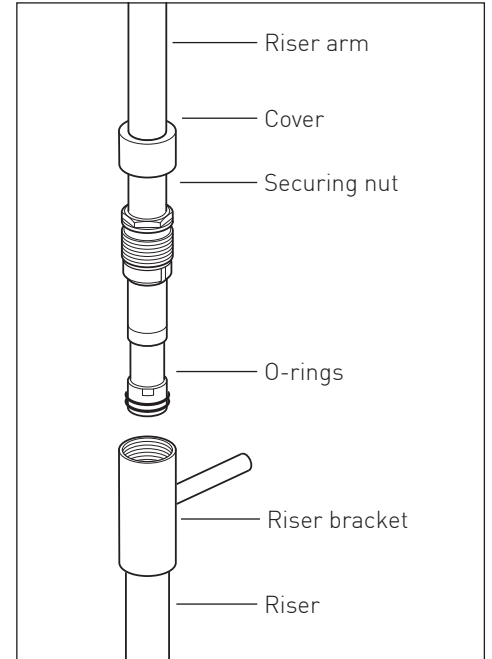

Remove the nut and seal from the top of the valve and slide onto the riser rail. Push the riser onto the connection on the top of the valve, slide down the seal and tighten the nut.

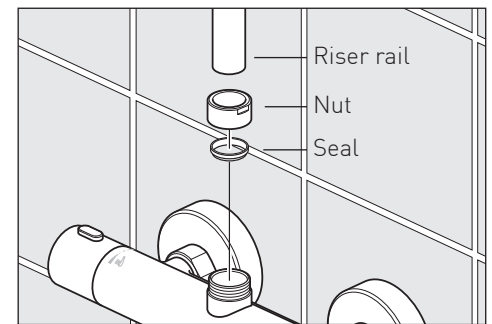

Slide the wall bracket onto the riser bracket.

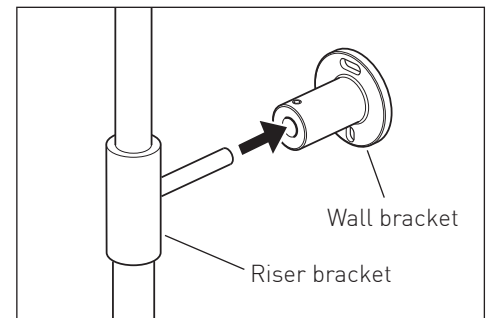

## Installation - Quick fit connectors

Slide on the olive, screw on and tighten the nut.

Before installation flush through the pipe work to ensure removal of debris, turn off the water supply.

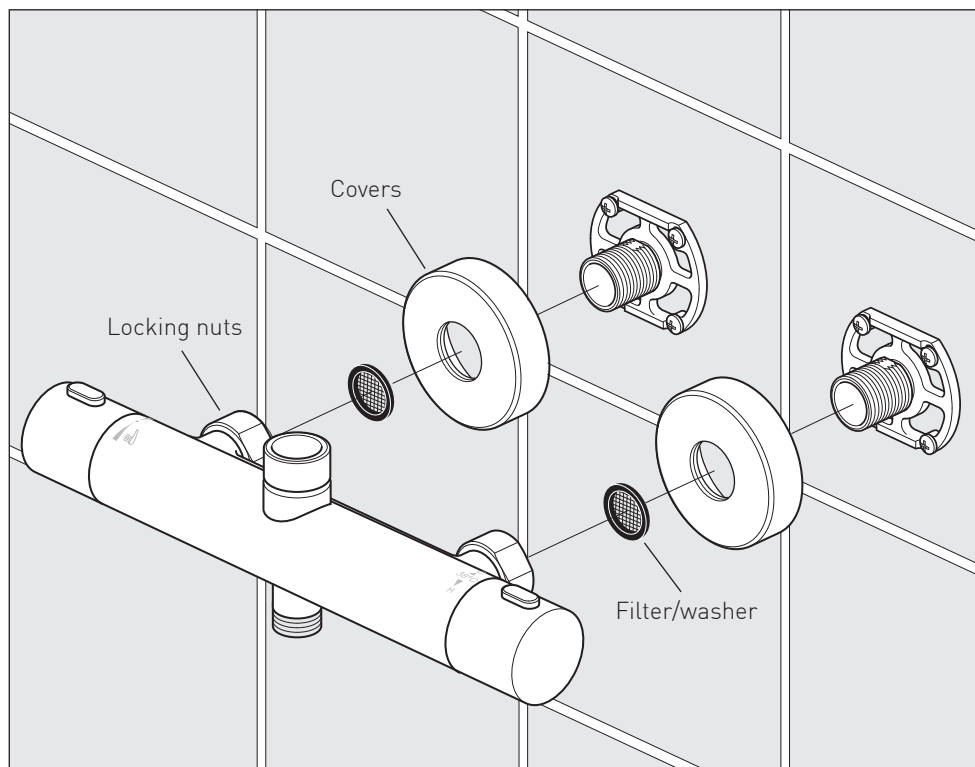
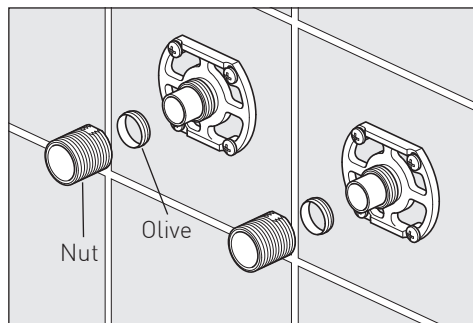

Screw the covers on each offset connector. Place a rubber filter/washer in each of the locking nuts on the valve and screw onto the connectors.

## Installation - Quick guide

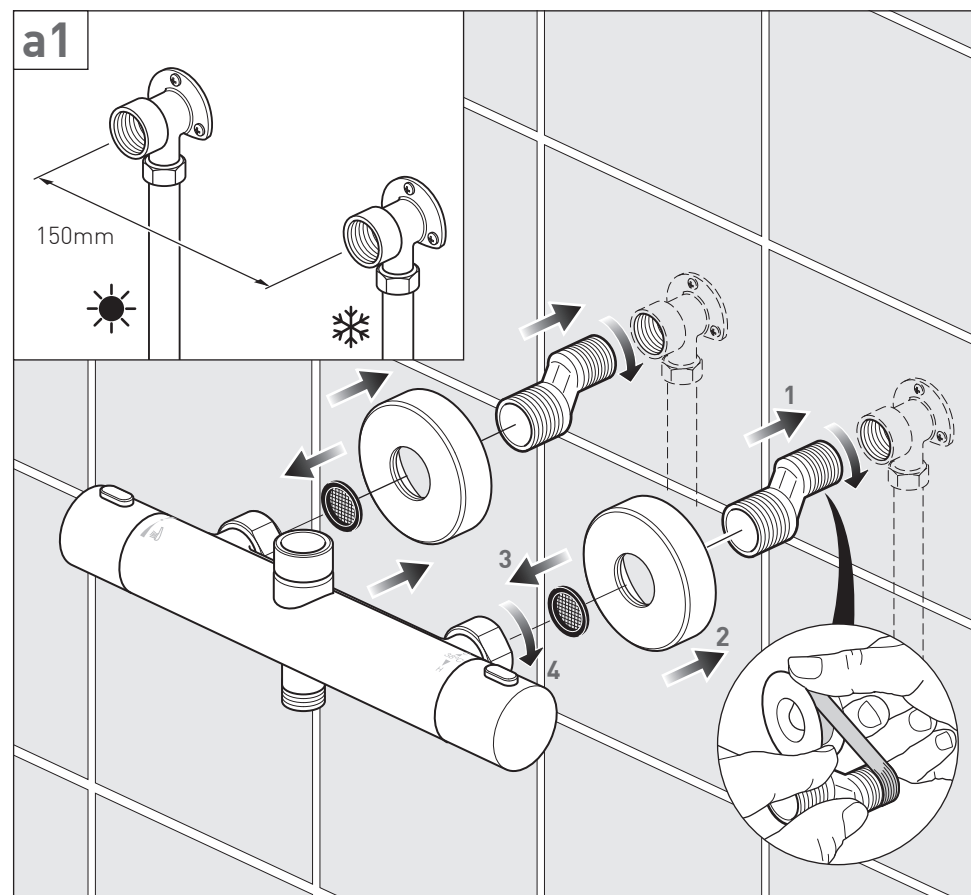
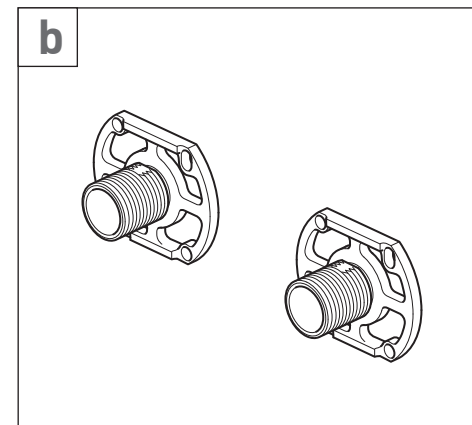
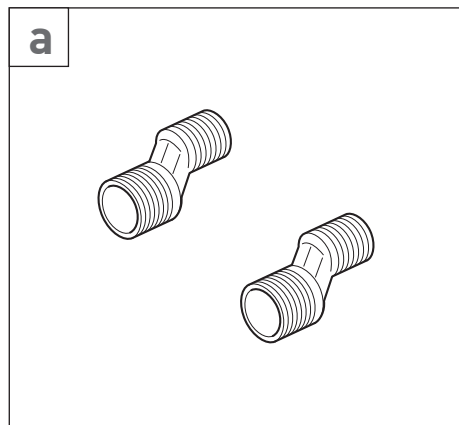

## Installation - Quick guide

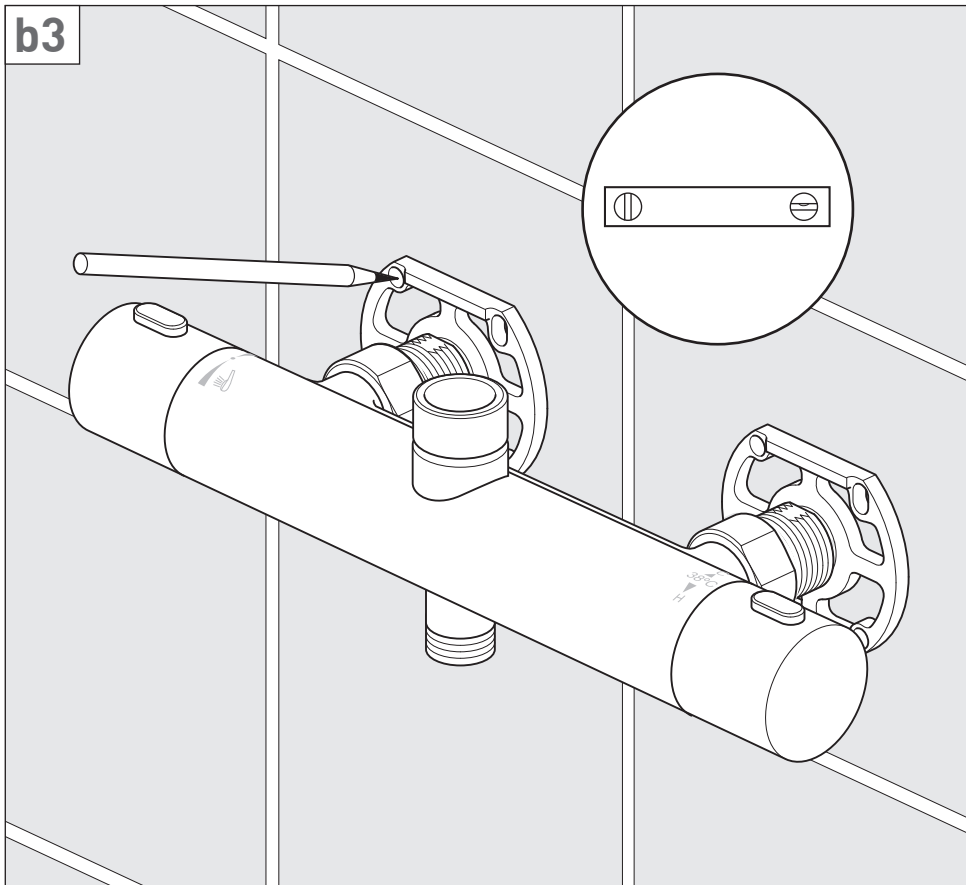
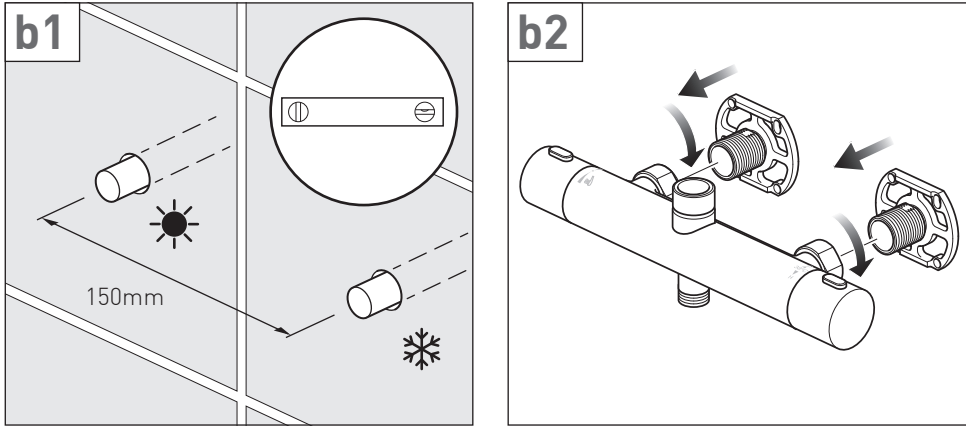

## Installation - Quick fit connectors

**Note:** Make sure that the valve is positioned to allow room for the riser rail to be fitted later (see dimensions on page 6).  
Prepare the wall with 2 copper pipes at 150mm centres. Connect the water supply to the inlet pipes. The hot water should be connected to the left hand pipe.

Temporarily screw both quick fit connectors onto the valve.

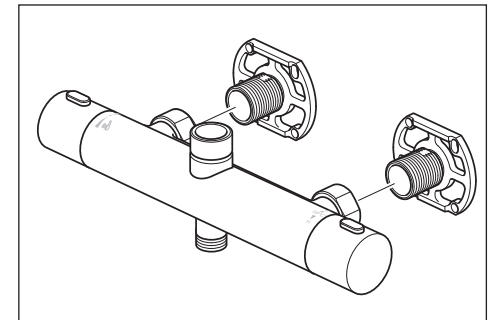
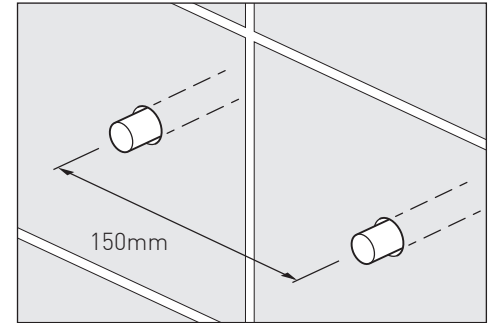

Position the valve making sure it is level and mark the position of the 4 screw holes in each connector.

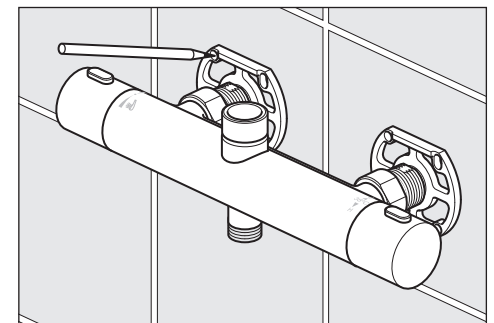

**Warning!** Please check for any hidden cables and pipes before drilling holes in the wall.  
Remove the nut and olive from the connector.  
Drill the 4 marked holes to a suitable depth for the wall plugs and secure with supplied screws. Repeat for the other connector.

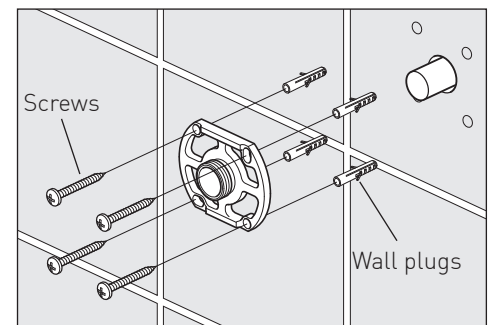



## Installation - Offset connectors

**Note:** There are two options for installing your valve, using offset connectors (below) or quick fit connectors (see page 13).

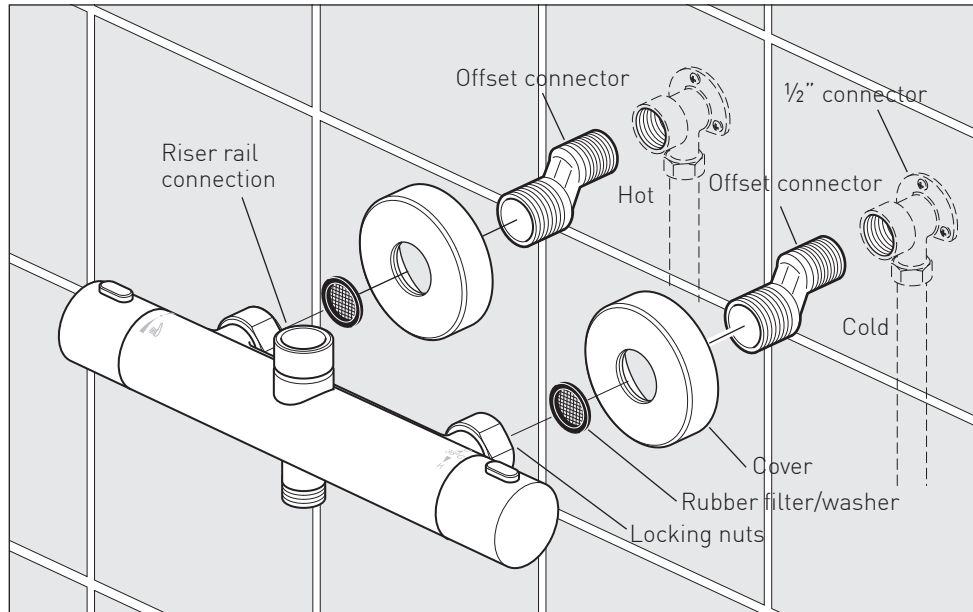

Before installing your new mixer, flush through the pipe work to ensure removal of debris, turn off the water supply.

**Note:** Make sure that the valve is positioned to allow room for the riser rail to be fitted later (see dimensions on page 6).

Prepare the wall with 2 flush 1/2" connectors at 150mm centres. Connect the water supply to the inlet pipes. The hot water should be connected to the left hand pipe.

Using PTFE tape screw on the 2 offset connectors followed by the covers.

Place a rubber filter/washer in each of the locking nuts on the valve and screw onto the connectors, some adjustment can be made to the offset connectors to align the centres and level up the valve.

**Note:** The valve must be connected to rigid pipe work for support.

## Installation - Quick guide

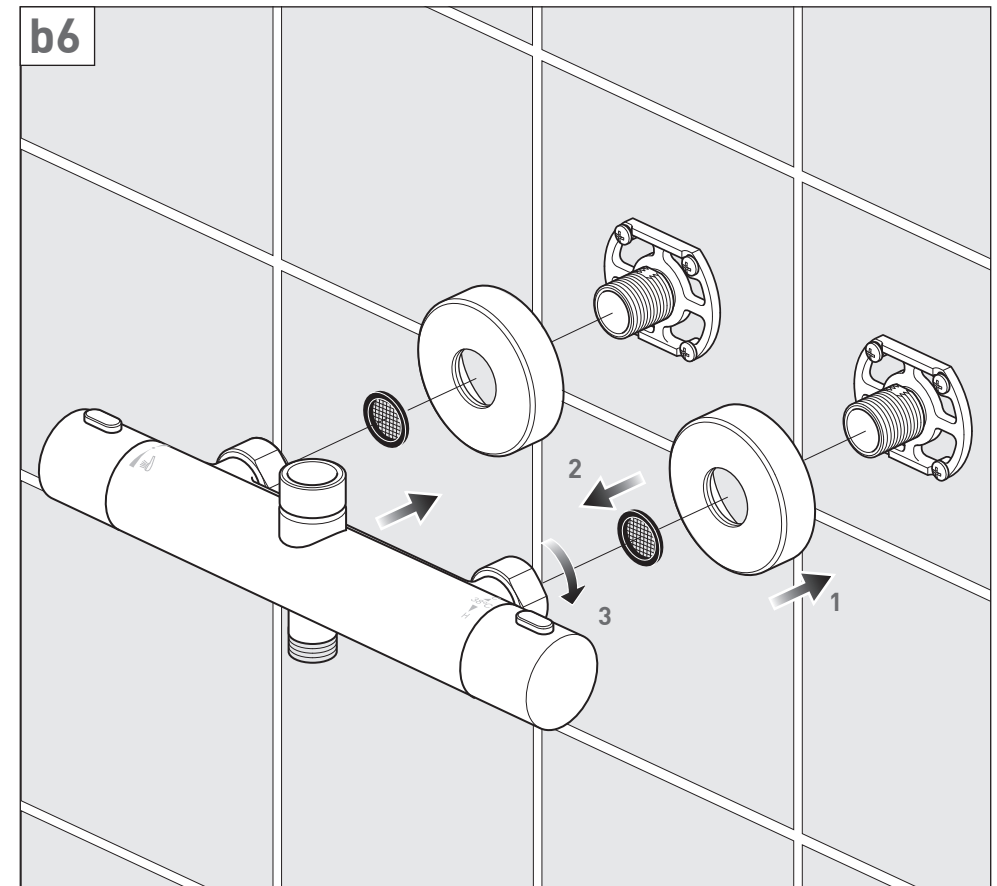
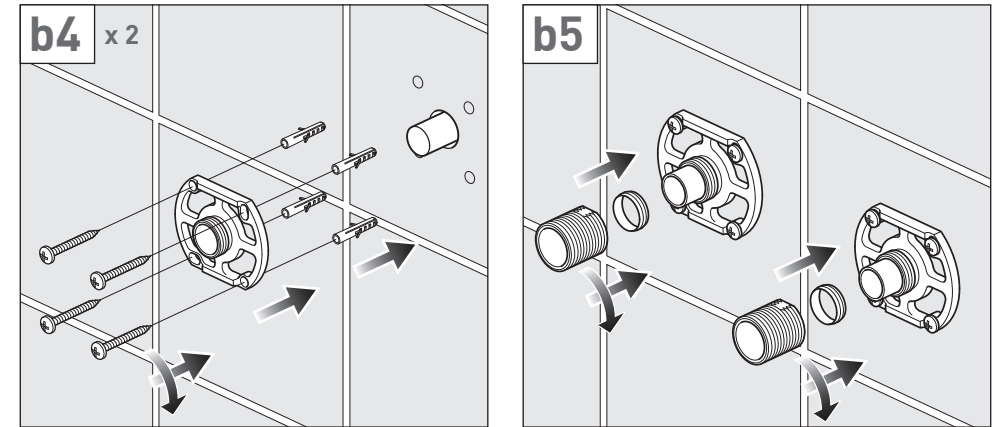

# Installation - Quick guide

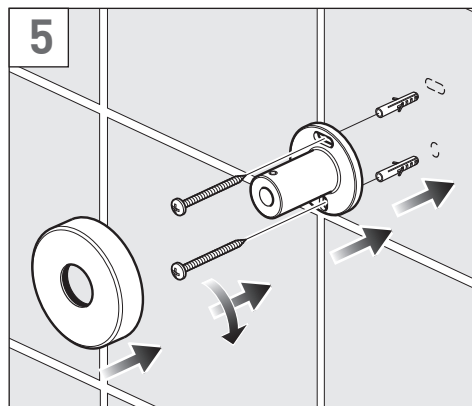
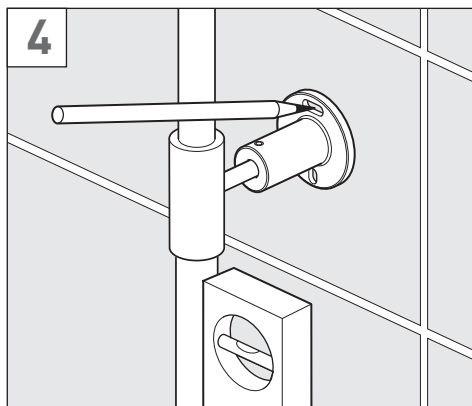
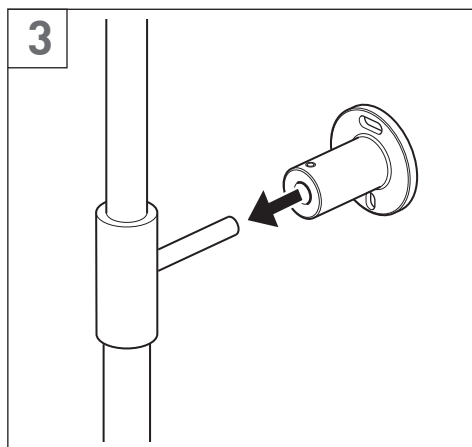
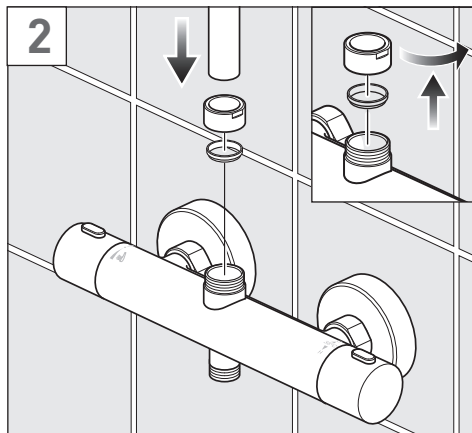
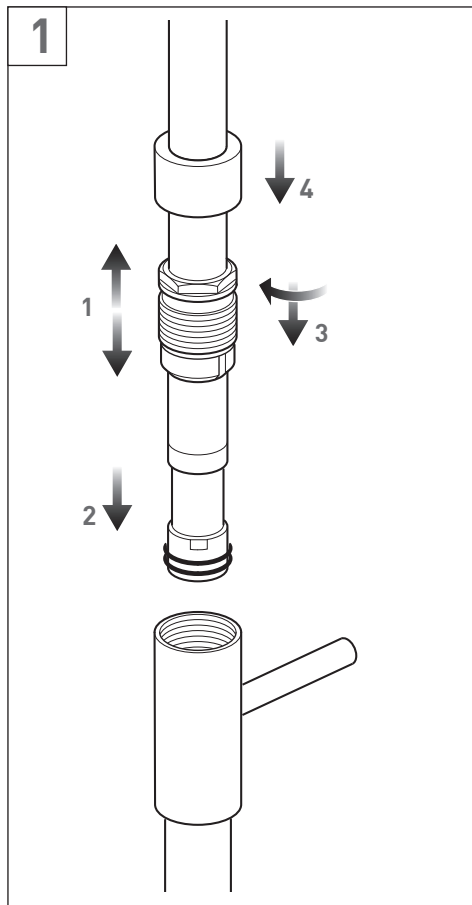

# Installation - Quick guide

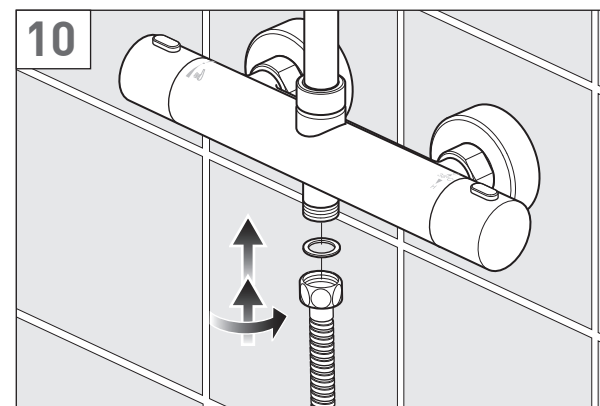
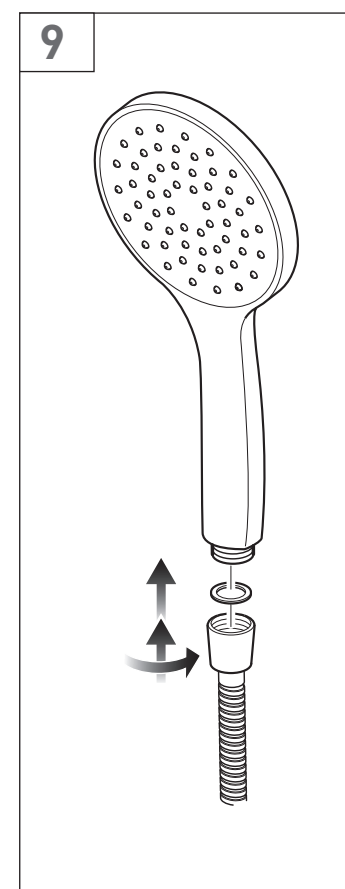
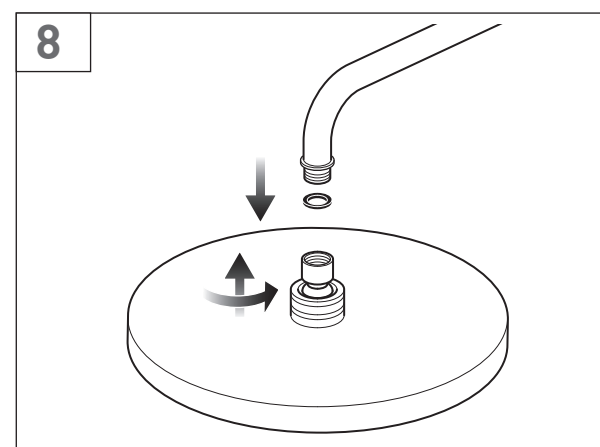
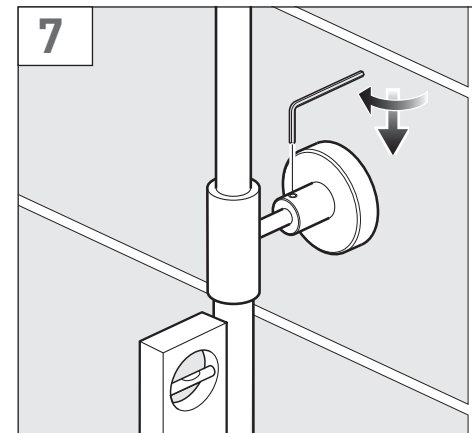
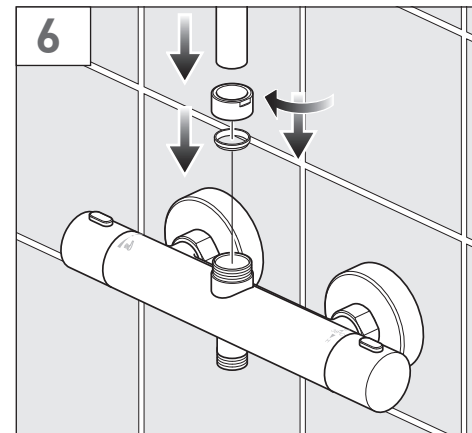

# Guarantee

All VADO products come with a 2 year guarantee as standard. Within this guarantee period VADO will provide replacement parts and any labour **[SEE NOTE 1]** needed to complete the product repair.

This standard guarantee may be extended by registering your product to give up to a 12 year guarantee period. Once registered:

VADO chromed brassware and stainless steel products have a 12 year guarantee (2 years parts and labour plus 10 years parts only).

VADO Sensori Smart Touch and Smart Dial products have a 5 year guarantee (parts and labour).

VADO Identity and i-tech products have a 5 year guarantee (2 year parts and labour plus 3 years parts only).

All other VADO products have a 3 year guarantee (2 years parts and labour plus 1 year parts only)

## **[SEE NOTE 2]**

VADO electric showers have a 2 years parts and labour guarantee.

### **Guarantee conditions**

Our products are guaranteed against manufacturing defects from the date of purchase until the expiry of the relevant guarantee period shown above.

The guarantee is only valid if:

- The product has been installed, used and maintained in accordance with VADO's instructions and subjected to normal use only.
- The defect is not due to use of an unsuitable or inadequate water or power supply.
- The defect is not due to accident, misuse, neglect or incorrect/inappropriate repair (other than by VADO or VADO authorised agents) or damage caused by foreign objects or substances.
- The extended guarantee is only available if you have completed the Guarantee Registration Process. This can be done via the VADO website or via phone to our aftersales team. Registration must be completed within 6 months from date of purchase.

Under the extended guarantee period VADO will, at its option, offer to supply any replacement product (or component part) assessed to be defective **[SEE NOTE 3]**.

The guarantee (whether standard or extended) is non-transferable to any subsequent owner. All claims under the guarantee should be notified in the first instance to our Aftersales department, contact details below, this must be done no later than the last day of the relevant guarantee period. All claims must be accompanied by proof of purchase (sales receipt or delivery note) from an official VADO dealer.

The guarantee does not extend to any consequential loss or damage.

After repair or replacement, the relevant guarantee period will be calculated from the original date of purchase.

VADO operates a policy of continuous product development and therefore reserves the right to change the product, packaging and documentation specifications without notice.

### **NOTES:**

**[1]** Labour via our engineer network is only available in the UK. Attendance by a VADO engineer or sub-contract engineer will be under our standard terms and conditions.

**[2]** VADO spare parts and shower hoses are under a parts only guarantee.

**[3]** VADO reserves the right to charge in advance for a product (or replacement part) pending collection and investigation (at VADO expense) to confirm a defect is due to a manufacturing issue. If a defect is found the charge will be refunded or cancelled. This guarantee is in addition to and does not affect your statutory rights as a consumer.

Tel: 01934 745163

Email: aftersalescare@vado.com

# VELO

Thermostatic shower valve with adjustable rigid riser

User Guide

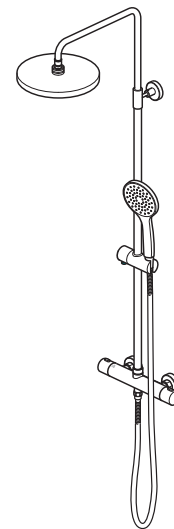

## WHERE INSPIRATION FLOWS

Note: for illustrative purposes only the VEL model is shown. Please use this manual for Aquablade and Atmosphere products as well.

Please leave with the end-user



# Welcome

## Thank you for choosing VADO

Our products can be found in some of the most prestigious hotel, commercial and residential developments across the world, therefore you can expect exceptional product quality and outstanding customer service.

This product has passed through stringent quality assurance processes coupled with demanding lifecycle mechanical testing to ensure it reaches the exacting standards that allow us to offer our premium 12 year guarantee.

We work to ensure our product designs are harmonious with all sanitaryware, so when you choose VADO, your choice of coordinating items is unlimited.

**With VADO, you can really let your inspiration flow.**

For any technical or operational queries please contact our experienced aftersales team on 01934 745163.

**Vado**, Wedmore Road, Cheddar, Somerset, England BS27 3EB  
tel 01934 744466. fax 01934 744345  
aftersales@vado.com  
www.vado.com

# Parts:

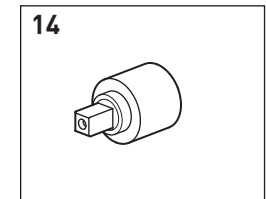
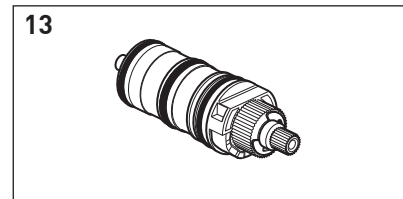
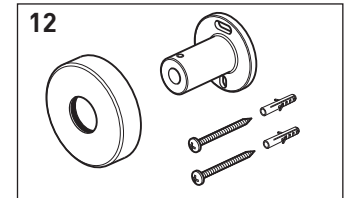
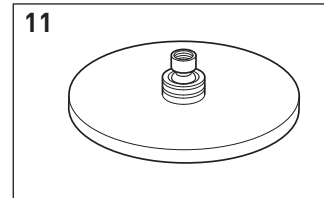
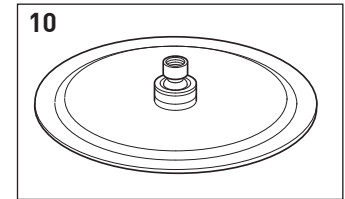
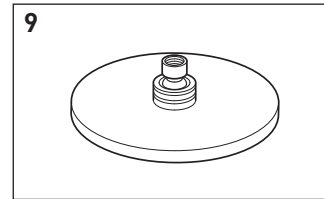
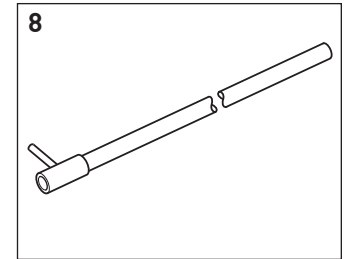
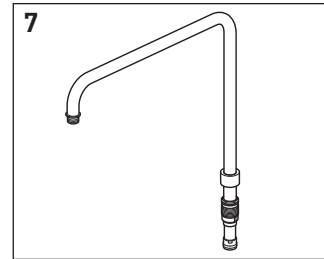

## Parts list:

Item	Description	Part Code
7	Top riser	VEL-149R0-RISER
8	Rail	VEL-149R0/RAIL-CP
9	VEL Saturn shower head	WG-SATURN2-CP
10	AQB Aquablade shower head	AQB-RO/30-CP
11	ATM venturi aerated shower head	ATM-HEAD/RO/B-CP
12	Riser bracket	VEL-149/R0-BRACKET
13	Thermo cartridge	V-001B-PLA
14	Diverter	VEL-002B-PLA

## Operation - riser rail

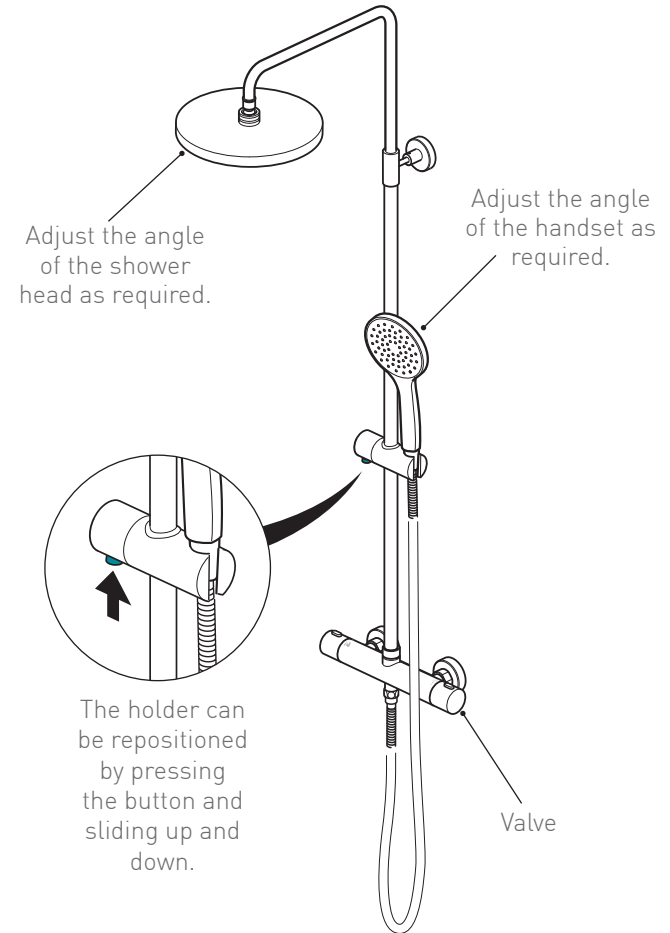

# Operation - valve

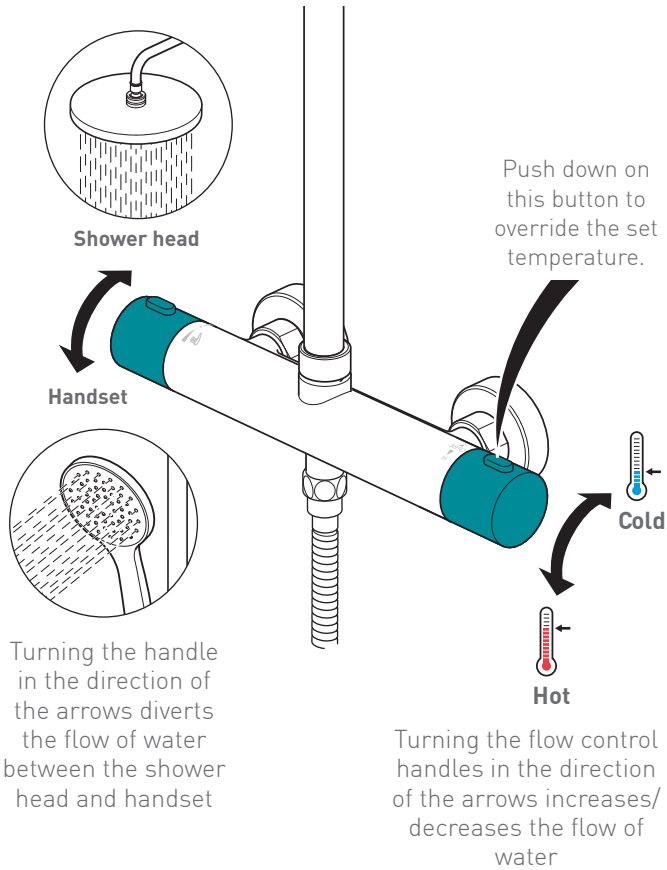

# Parts:

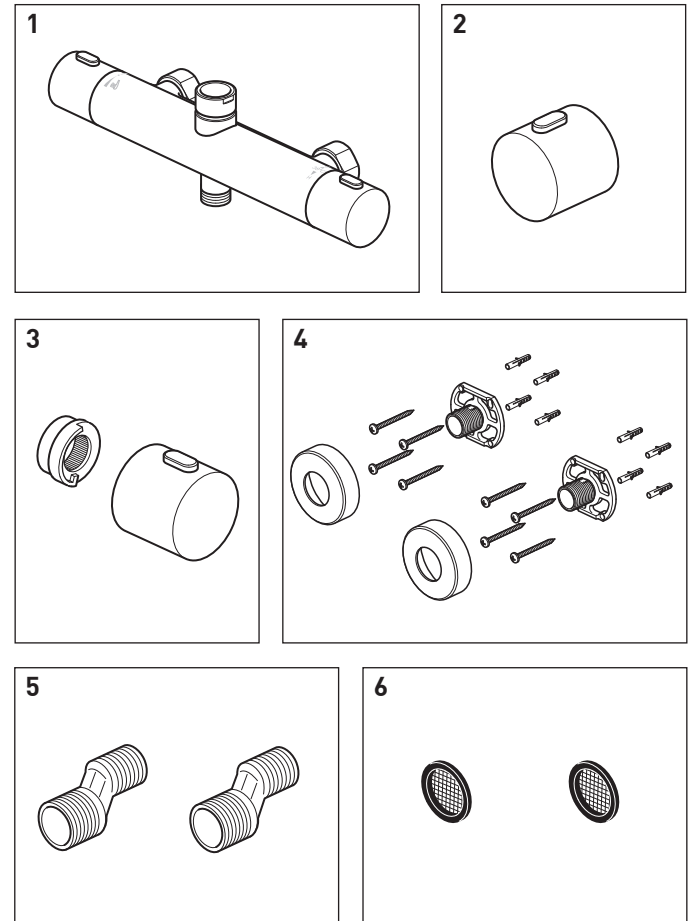

## Parts list:

<b>Item</b>	<b>Description</b>	<b>Part Code</b>
<b>1</b>	Bar valve	VEL-149RO-CP
<b>2</b>	Flow handle	VEL-4/FLOW2-CP
<b>3</b>	Temperature handle	VEL-4/TEMP2-CP
<b>4</b>	Fast fit brackets	VEL-FFBRACK-RO-CP
<b>5</b>	Off-set connectors	VEL-149-CONNECTORS
<b>6</b>	Filter washers	VEL-149-WASHERS

**Please continue overleaf.**

## Cleaning instructions:

The electroplating on this product is finished to the highest standard. Due care needs to be taken to ensure the appearance is retained.

We recommend cleaning all products with a soft damp cloth **ONLY** and advise strongly against the use of all aggressive/corrosive cleaning products i.e. powders and liquids. If these instructions are not followed, this may invalidate your guarantee in the event of a problem occurring.

## Commissioning

The valve has been factory set under balance pressures and hot water supply at 65°C. When your specific operating conditions are significantly different from the above, the temperature of the water may vary from the setting.

When the difference is too great, you can adjust the calibration of the valve to suit individual requirements of the installation:

1. Check the temperature of the water being delivered from the outlet with a thermometer.  
**Note:** temperature readings should be taken at normal flow rate after allowing for the system to stabilise.
2. If the temperature is not 38°C proceed to reset the calibration as follows.

Remove the handle.

Ensure the step on the stop ring is located at 12 o'clock. Do not remove the plastic stop ring. Turn the spline of the thermostatic valve clockwise to decrease the temperature and anti-clockwise to increase the temperature until 38°C is achieved at outlet.

**Note:** the sensing part of the thermometer probe must be fully submerged in the water that is to be tested.

Replace the handle making sure that the pin is against the step.

Once the handle has been attached ensure the temperature does not exceed 46°C when turned entirely anti-clockwise.

Your valve setting is now commissioned.

## Disposal - please read:

DO NOT dispose of this unit with normal household waste, take to a local authority recycling centre.



## Maintenance

### Thermostatic cartridge

To clean the filters, you must first remove the cartridge from the housing.

Removing the Cartridge:

1. Check water has been isolated.
  2. Remove the stop ring by carefully pulling away from the valve.
  3. Remove the locking nut using a 22mm box spanner or long nose pliers and pull out the thermostatic cartridge.
  4. Clean filters by rinsing them under running water to remove any debris.
  5. If there is limescale deposits then it is recommended to immerse the cartridge for a few minutes in 50% white vinegar + 50% hot water, brush the filters gently and then rinse under running water to clean all particles. If this is not effective, a replacement cartridge should be fitted.
  6. Before reassembling the cartridge, clean its housing with a wet cloth and grease the 'O' rings using a suitable silicone grease.
  7. Reassemble the cartridge into the body, then place the plastic stop ring onto the cartridge with the stop at the 12 o'clock position.
  8. Turn the water supply.
  9. Check the water temperature to ensure correct commissioning.
- See page 6 of this guide or [Vado.com](http://Vado.com) for commissioning.
10. Ensure that the stop on the stop ring is at 12 o'clock and replace the handle with the temperature override button also pointing at 12 o'clock being careful not to turn the spline of the valve.

## Commissioning

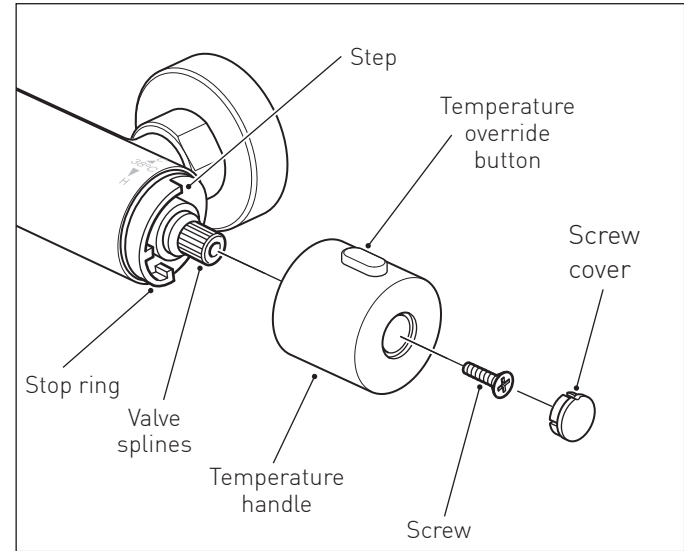

## Maintenance

We advise that the below is carried out annually as failure to do so may result in invalidation of warranty.

### Isolating the thermostatic valve

**IMPORTANT:** Please see the below procedure for isolating the thermostatic valve.

1. Isolate the incoming hot and cold water to the valve.
2. Turn shower valve on (left handle) to check isolation, please ensure that your body/hands are not under the flow of water as there is a potential for delivery of hot water.
3. Remove temperature control handle and temperature stop ring (essential).
4. With shower in the on position, replace temperature handle on thermostatic Valve (ensure temp stop has been removed).
5. Turn temp handle fully anti clockwise until stop point is reached and can be turned no further , please ensure that your body/hands are not under the flow of water as there is potential for delivery of hot water if isolation has been unsuccessful.
6. Turn temperature handle fully clockwise until resistance is felt.
7. If there is no flow of water coming from the outlet during both points 5 and 6 isolation has been successful, you may now remove and maintain the cartridge.
8. If at any of the above point's water continues to flow please isolate at an alternative point within the system for both hot and cold and repeat points 2-8.

## Maintenance

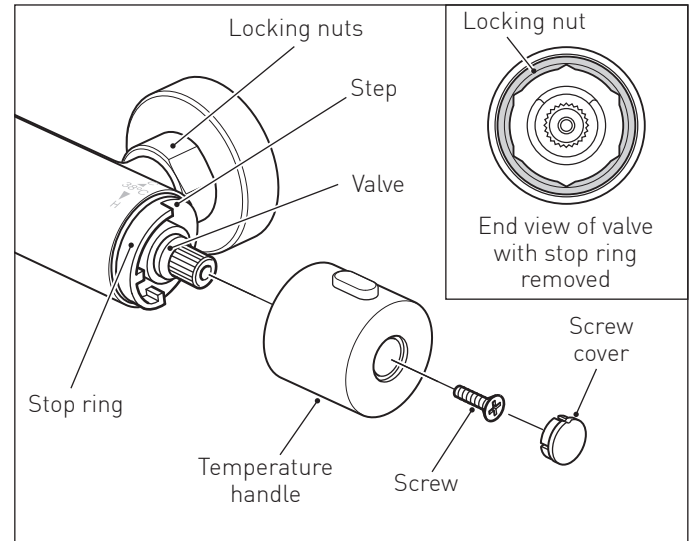

This thermostatic valve is fitted with a double filtering facility. Filters are fitted on the water inlets and on the thermostatic cartridge.

Depending on the water quality, filters may become dirty, causing reduced flow and inefficient working of the valve.

### Inlet filters

Check water has been isolated. Undo both locking nuts at the back of the valve and remove from the wall. Pull out the filter/washer, rinse in water to remove the dirt, and then soak them in vinegar or descaling agent.