

WASHINGTON ACCESSORIES
Towel Rail

RAK
CERAMICS

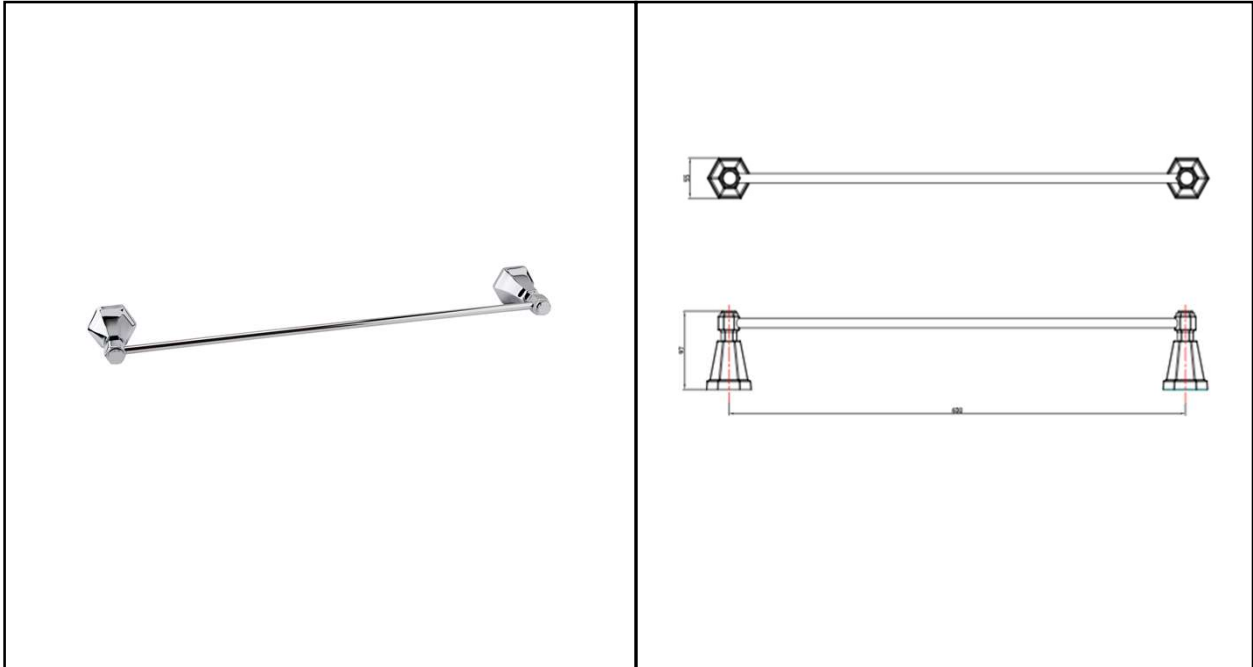

Dimensions: 600w x 97d x55h mm

Colour: CHROME

Code: RAKWTN9910

Warranty: 2 YEARS

Weight: 1.16 KG

Dimensions: All Dimensions in mm tolerance $\pm 5\%$ for below 200mm and $\pm 3\%$ for above 200mm.
Note: Due to a continuing development programme to improve design and performance the manufacturer reserves all rights to vary specifications without prior information.
Please note accessories are for photographic use only.