

CUSTOMER SPECIFICATION SHEET - BATHS

SALES CODE: BAU015

DESCRIPTION Fordham 1500 Slipper Freestanding Bath with Feet Set 1

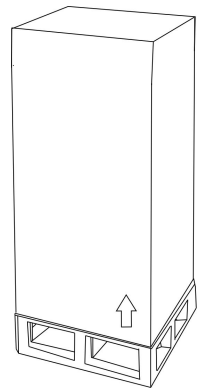
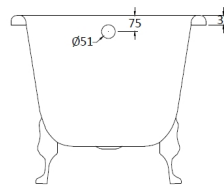
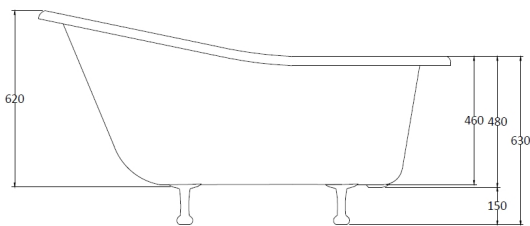
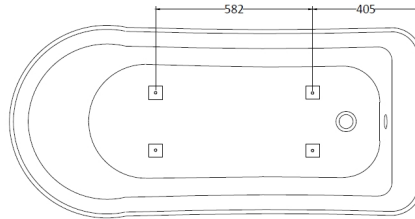
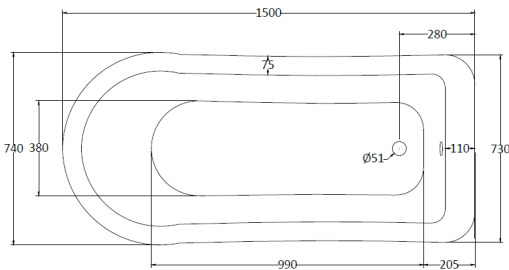

PRODUCT DIMENSIONS

Length (mm)	Width (mm)	Height (mm)	Nett Wgt Kg
1500	730	770/630	46

PACKAGING DIMENSIONS

Length (mm)	Width (mm)	Depth (mm)	Gross Wgt Kg
1580	780	635	46

PACKAGING DATA

Box Colour	Brown Cardboard Sleeve		
Box Qty	1	Label Colour	White Label
Label Size	100 X 50	Label Qty	2

OUTER BOX DIMENSIONS (If Applicable)

Length (mm)	Width (mm)	Height (mm)	Gross Wgt Kg
1570	680	500	58
Barcode			

PRODUCT DETAILS

Country of Origin	China	Certification	FSC	CE
Fitting Instruction	No	Material Colour Ref	European White	
Product Material	Acrylic	Material Thickness	14mm	
Volume (Ltr)	155L	Displaced Capacity	85L	
Leg Set Inc'	Including Feet Set 1	Waste Inc'	Waste Not Included	
Drilled/Undrilled	Undrilled For Taps	Includes Grips	No Grips Supplied	
Embossed	No	No of Tapholes	None	
Anti-Slip	No			

CUSTOMER SPECIFICATION SHEET - BATHS

SALES CODE: Leg Set 1

DESCRIPTION Leg Set 1

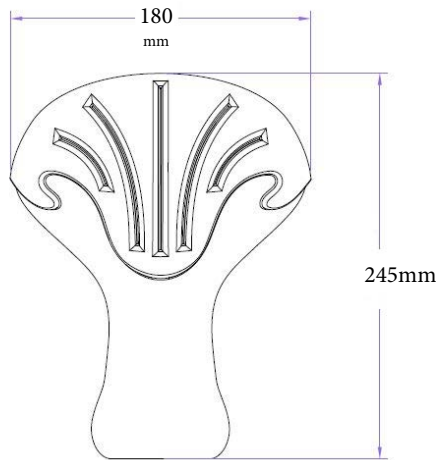

PRODUCT DIMENSIONS

Length (mm)	Width (mm)	Depth (mm)	Nett Wgt Kg
245	180	115	4.92

PACKAGING DIMENSIONS

Length (mm)	Width (mm)	Depth (mm)	Gross Wgt Kg
500	500	250	4.92

PACKAGING DATA

Box Colour	Polystyrene Moulded Box		
Box Qty	1	Label Colour	White Label
Label Size	140 X 100	Label Qty	1

OUTER BOX DIMENSIONS (If Applicable)

Length (mm)	Width (mm)	Height (mm)	Gross Wgt Kg
Barcode			

PRODUCT DETAILS

Country of Origin	China	Certification	FSC	N/A	CE	N/A
Fitting Instruction	No	Material Colour Ref	Not Applicable			
Product Material	Steel	Material Thickness	N/A			
Volume (Ltr)	N/A	Displaced Capacity	N/A			
Leg Set Inc'	Not Applicable	Waste Inc'	Not Applicable			
Drilled/Undrilled	Not Applicable	Includes Grips	Not Applicable			
Embossed	Not Applicable	No of Tapholes	Not Applicable			
Anti-Slip	Not Applicable					